

**UNIQUE MEDIA CONTAINMENT BY Flo-Tite**

**Lubricant/Sealing**

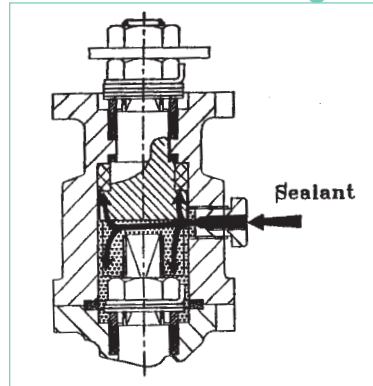

Flo-Tite M/C Cap can be adapted with a button head check valve to inject sealant providing an additional third seal or an emergency shut-off.

**Monitoring**

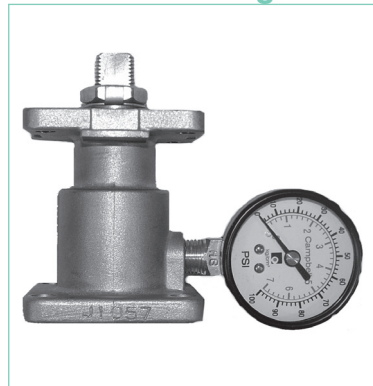

Strategically placed monitoring connection allows choice of sensitive pressure gauge and/or "Sniffer: sensing device for early detection of primary stem seal leak.

**Positive Displacement**

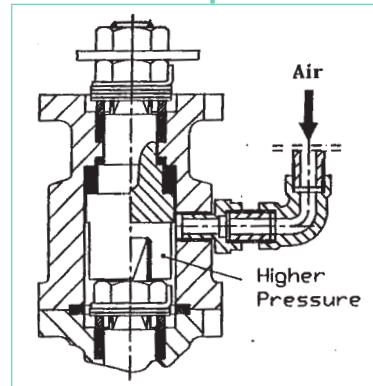

Air line may be permanently connected to our M/C Unit, providing a positive pressure supply to the M/C Cap that exceeds the valve line pressure. This will insure against the possibility of any valve stem leak to the atmosphere.

**DIMENSIONS:**

UNIT	A	B	C	D	E	F	G	ØP	U	W
MCU-1	1.97 50	2.32 59	1.17 29.7	1.17 29.7	0.24 6	0.54 14	0.25 6.4	0.38 9.5	#10-24	1/8"NPT
MCU-2	2.91 74	3.25 82.5	1.39 35.4	1.39 35.4	0.35 9	0.72 18	0.32 8	0.437 11.1	1/4"-20	1/4"NPT
MCU-3	2.91 74	3.35 85	1.95 49.5	1.95 49.5	0.43 11	0.9 23	0.38 9.5	0.625 15.9	5/16"-18	1/4"NPT
MCU-4	4.53 115	6.06 154	3.54 90	1.87 47.6	1.75 44	3.05 77	0.67 17	1.1 28	1/2"-13	1/4"NPT
MCU-5	7.22 183	8.87 225	3.38 85.7	3.38 85.7	1.65 42	3.61 91	1.02 26	1.71 43.5	1/2"-13	1/4"NPT

**VALVE SIZE SELECTION**

Unit	F150/F300 300/200 T75	RF150
MC - 1	1/4 - 3/4 6 - 20	--
MC - 2	1 - 1 1/4 25 - 32	--
MC - 3	1 1/2 - 2 40/50	2 50
MC - 4	2 1/2 - 4 65 - 100	3 - 6 75 - 150
MCU- 5	6 - 8 150 - 200	8 - 10 200 - 250

**BILL OF MATERIALS:**

ITEM	PART NAME	MATERIAL	QTY.
1	Body Housing	A351 Gr CF8M	1
2	Stem	SS316	1
3	Washer Protector	PEEK	1
4	Thrust Washer	50 / 50	2
5	Gland Nut	SS304	1
6	Belleville Washer	SS301	2
7	Lock Washer	SS304	1
8	Packing Gland Sleeve	SS301	2
9	Packing Protector	PEEK	1
10	Stem Packing	RPTFE/Graphite	3/1
11	Gasket	RPTFE/Graphite	1

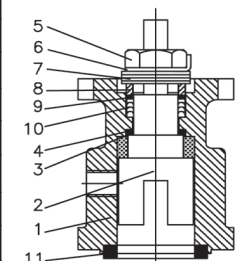
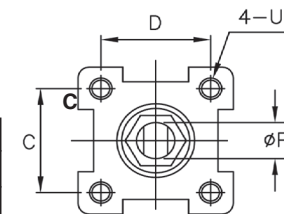
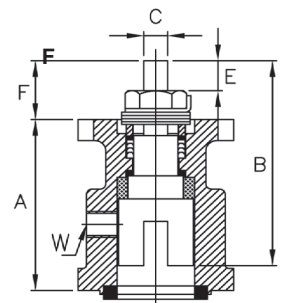

This brochure is general in nature and manufacturer reserves the right to alter materials or to make design improvements.

**MEDIA CONTAINMENT CAP**

**A Modular Design Multi-Purpose Device That Addresses:**

- Maintenance Control
- Emission Control
- Secondary Seals
- High Temperature Safety
- Cryogenic Applications



Models F150/F30 (2 PC Flanged) Models 200/300 (3 PC) Models SF150 (1 PC)

**Dangerous High Temperature Severe Service Applications**

**Severe Service Design**

Flo-Tite's Media Cap unit provides an added safety feature with the addition of a secondary set of graphite stem packing with a live-loaded design using Belleville washers that automatically compensate for temperature and pressure fluctuation, maintaining a leak proof seal for an extended cycle life. The units added height, help distancing the valve operator from dangerous high temperature media.

**Control Maintenance**

Flo-Tite's valves with I-SO-Mount pads are designed to accommodate the use of our media-cap. An ideal economical solution to reduce costly down time, due to unscheduled maintenance repairs on ball valves. In many plant environments valves with stem leaks must be shut down for immediate repairs, these unscheduled repairs in many systems will cost the plant many times more than the actual installed ball valve. There is no way for Flo-Tite to calculate your lost production cost due to valve repair. Flo-Tite's media-cap seals off unlikely valve stem leaks easily and quickly in line and under pressure.

Field mounts to standard valves with I-SO-Mount Pad. Either at the factory or in the field onto existing Flo-Tite ball valves. Designed for both automated and manual service.

**Address Concerns of Tomorrow With A Valve Built For Today**