



LADISH VALVES

CONTROLLED QUALITY • CORROSION RESISTANT

TO MARK PROGRESS

API 602 Forged Steel Valves

CATALOG 221

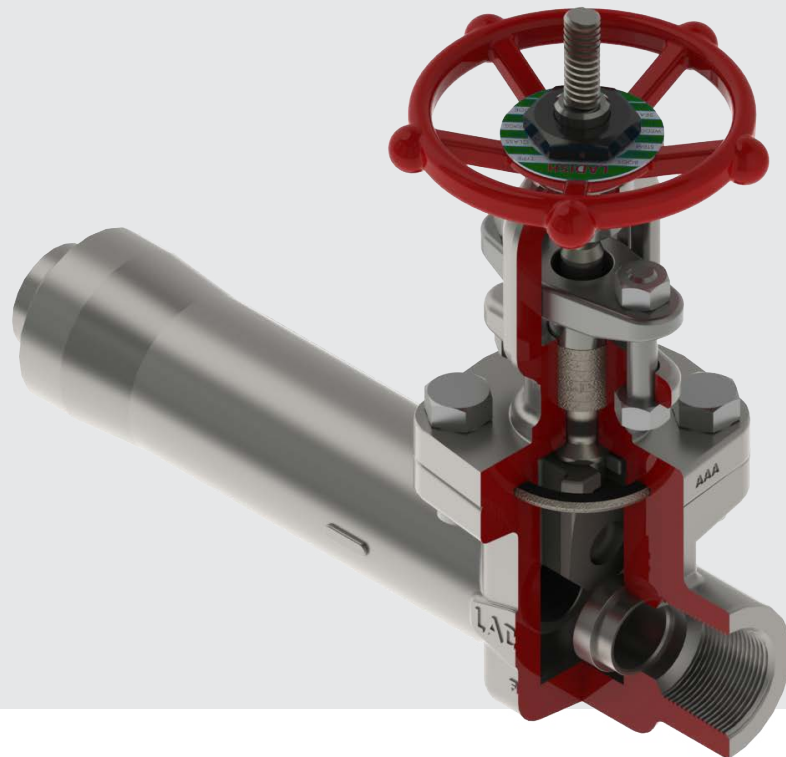

📍 7603 Bluff Point Dr., Houston, TX 77086

☎ 281.880.8560

🖱 ladishvalves.com

✉ sales@ladishvalves.com



PRINTED IN THE USA • 2019

TABLE OF CONTENTS



Ladish Valves—A Heritage Brand	3
Ladish Product Line Overview	4
Ladish Valves — Why We’re Different	5
Overview	7
Gate Valve	8-9
Gate Valves – Takeoff and IREB Valve	10-11
Globe Valve	12-13
Check Valves – Piston and Swing	14-15
Bellows Seal Gate Valve	16-17
Bellows Seal Globe Valve	18-19
Bellows Seal Dimensional Data	20
Bellows Seal Design Highlights	21
Bellows Valves	22
Fugitive Emissions	23
How To Order Your Forged Steel Ladish Valve	24–25



LADISH MALT
LADISH MALTING CO.
MILWAUKEE, WIS.

THERE IS
NO SUBSTITUTE
FOR FINE

Malt

THE LADISH MALTING CO. MILWAUKEE, WIS.

1. HEAT CODE PROTECTION—Heat code protection is provided by the use of a special heat resistant material which is available in a variety of sizes and shapes to meet the requirements of specific heat treating applications.
2. FULL RANGE TEMPERATURES—Heat code protection is available in a full range of temperatures from 100° to 1000° F.

SELECTED BY THE SON

LADISH

QUALITY

FLOUR

LADISH

CORROSION RESISTANT

VALVES

VALVES
LOW
ON
STEEL
BRASS
COPPER





TO MARK PROGRESS

LADISH VALVES

A Heritage Brand

Herman W. Ladish was born in Milwaukee, Wisconsin in 1880 and began his career in the bustling malting industry at the age of 16. Herman quickly established himself in the business, climbing the corporate ladder and assuming the role of superintendent at The American Malting Company. Ladish folklore has it that Herman's interest in metalworking was born from a problematic crankshaft that consistently halted production. Herman's search for an alternative manufacturing method led him to metal forging, and the birth of a metal working conglomerate of forgings, flanges, fittings and industrial valves was born.

Today, Ladish Valves is proud to have a history dating back to 1961 in Cynthiana, Kentucky. After experiencing a crippling flood of the Ohio River and several changes in ownership, Ladish Valves moved its headquarters to Houston in 2007.

With a foundation of more than 60 years of industrial valve production, Ladish Valves continues to be the industry benchmark for stainless steel and high nickel alloy industrial valves. The Ladish Valves trademark symbolizes a reputation that is emblematic of the highest quality standards, unmatched design and metalworking craftsmanship. Our history is important to us and we pay homage to it daily.

The Ladish Valves product line is specifically designed and manufactured to meet the stringent demands of the most corrosive service environments and high temperature applications. Our product is produced under rigorous metallurgical and manufacturing controls that assure a consistent, high degree of performance and dependability. The quality of the material we receive is critical to the quality of our product. With domestic source foundries and strictly monitored international vendors, Ladish Valves is relentless about the quality of materials sourced from its vendor community.

WHAT IT MEANS TO MARK PROGRESS

Ladish Valves is a responsive company that prides itself in being "local" with an exhaustive commitment to our customers and our product.

This means that no matter where you are, our team in Houston will provide a customized, clear response in a timely manner.

We pride ourselves in serving our customers and taking on the challenges of unconventional projects.

LADISH COMPLETE LINE OF PRODUCTS

Manufactured to the Ultimate in Quality Standards

WIDE RANGE OF VALVE TYPES, SIZES, RATINGS AND MATERIALS

Processes

CAST-FORGED-BAR STOCK

End Types

THREADED ENDS
 SOCKET ENDS
 FLANGED ENDS
 BUTTWELD ENDS
 FLAT FACE ENDS

Handwheel Options

RISING HANDWHEEL
 NON-RISING HANDWHEEL

Disc Options

SOLID WEDGE DISC
 FLEX WEDGE DISC
 SPLIT WEDGE DISC
 PLUG DISC
 TEFLON DISC

Size and Class Options

1/2"–36"
 CL150 – CL2500

Materials

STAINLESS STEEL
 ALLOY 20 – DUPLEX
 HIGH NICKEL ALLOY
 TITANIUM – ZIRCONIUM
 CARBON CHROME
 LOW TEMP

Ladish Product Line Catalogs

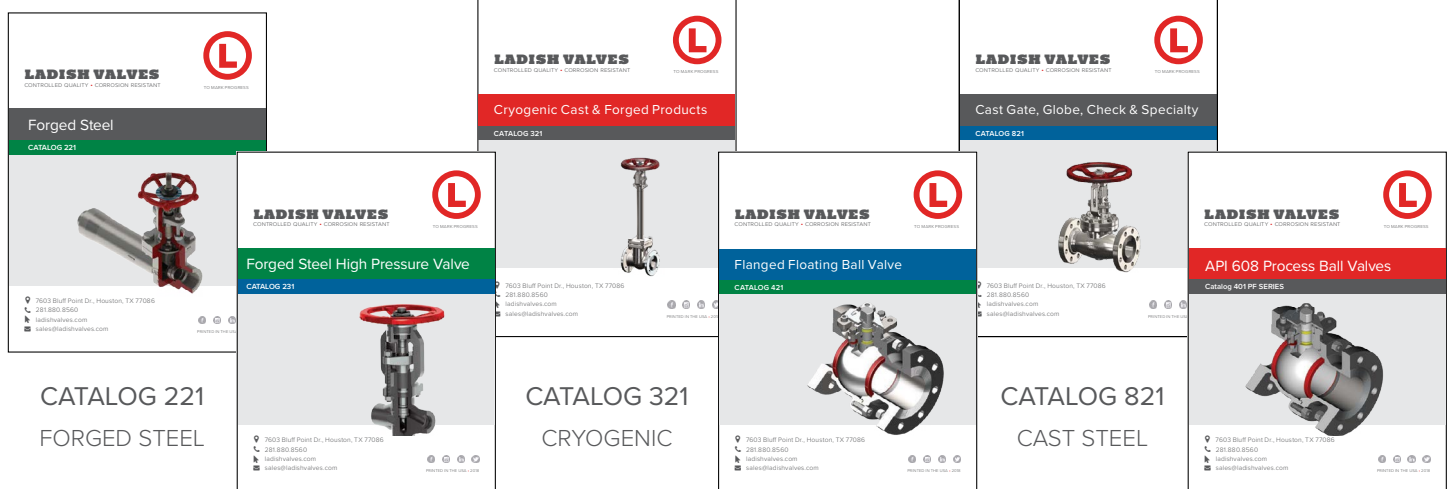

CATALOG 221
FORGED STEEL

CATALOG 231
HIGH PRESSURE

CATALOG 321
CRYOGENIC

CATALOG 421
FLOATING BALL VALVE

CATALOG 821
CAST STEEL

CATALOG 401 PF
PROCESS BALL VALVES



TO MARK PROGRESS

LADISH VALVES

Why We're Different

One-stop Manufacturing, Controlled Quality.

Ladish Valves is a premier manufacturer of multi-turn and quarter-turn valves. Our valves are widely used in the chemical and petrochemical markets, spanning from upstream extraction through midstream transportation and downstream processing. Ladish has a long history of supplying products to these markets, in addition to the power and pulp & paper industries.

Ladish has a full complement of value-added services to address the many challenges that often delay projects. Our team specializes in quick turnaround deliveries—even on challenging orders—with the confidence of controlled quality through in-house design and manufacturing.

We're a Step Above the Competition. Here's Why.

Ladish is local. Our manufacturing facility is located in Houston, giving us the flexibility to design, machine, assemble, test, verify and expedite our customers' orders—setting us apart from everyone else. Our other differentiators include:

- One of the largest (stocked) stainless and exotic alloy inventories in the U.S.
- In-house machining: Cryo extensions, end connections, modifications, etc.
- Same-day deliveries available
- Custom valve solutions using Ladish engineering & design teams
- Fully compliant clean room (oxygen, chlorine, hydrogen peroxide and others)
- Extensive in-house NDE capabilities

CATALOG 221 FORGED PRODUCTS

Catalog 221 serves to highlight the Ladish Valves line of forged multi-turn product. The products featured within include our forged API 602 gate, globe and check valves, as well as our bellows seal and cryogenic valves.



GATE



GLOBE



SWING

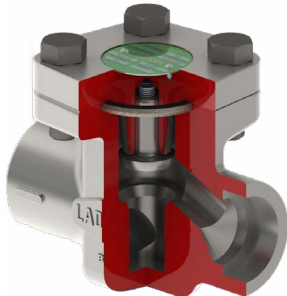

LIFT



CRYOGENIC



BELLOWS SEAL

FORGED PRODUCTS

FOR THE PETROCHEMICAL INDUSTRY

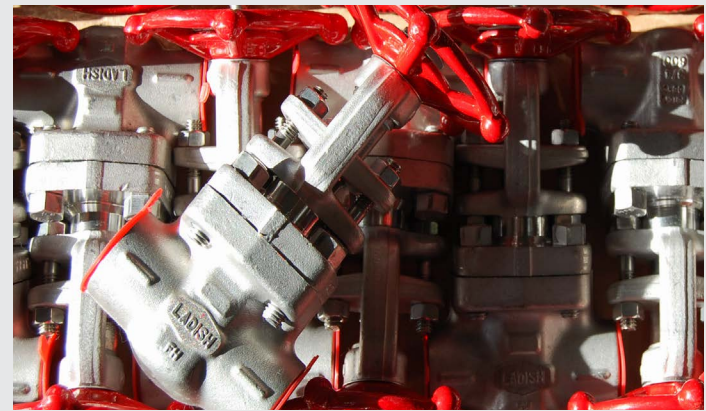

Ladish Valves stocks these valves in a variety of materials from carbon steel to nickel alloy and pressure classes ranging from 150 to 4500. In addition, both reduced and full ports and welded or bolted bonnet joints are available. Our 80,000 sq ft facility allows for inventory storage, product testing and material conformance control. With in-house NDE capabilities and fully integrated machine shop, quick deliveries and unconventional customer requirements are achieved in a timely, quality controlled manner.

The Ladish Valves forged product line is manufactured in a dedicated, state-of-the art facility in South Korea. The complex consists of over 30,000 square feet of manufacturing and warehouse space.

On-site testing capabilities includes bellow testing per MSS SP-117, cryogenic testing, API-598 pressure testing and liquid dye penetrant testing.

The facility carries a certified ISO-9001 quality system, CE-PED certification and an API 602 designation.

Ladish Valves has prided itself in making environmental responsibility one of our chief company goals. Our complete forged product line has completed API 624 compliance testing and is tagged as such.



FORGED STEEL GATE VALVES

Design & Construction

- API 602, ASME B16.34
- Bolted and welded bonnet available
- Full and reduced port available
- Threaded, socket weld, butt weld ends class 800 and 1500
- Flanged ends class 150 to class 450
- Hard facing on seating surfaces available.
- Bonnet constructed of forged steel with integral backseat.
- Bolted body-bonnet joint fully enclosed gasket design, both on ID and OD, allows for leak tight design.
- Welded body-bonnet joint connection is butt weld end joint with a full strength weld.
- Nameplate serialization for full traceability.
- API 622 and API 624 qualified packing for low fugitive emissions.

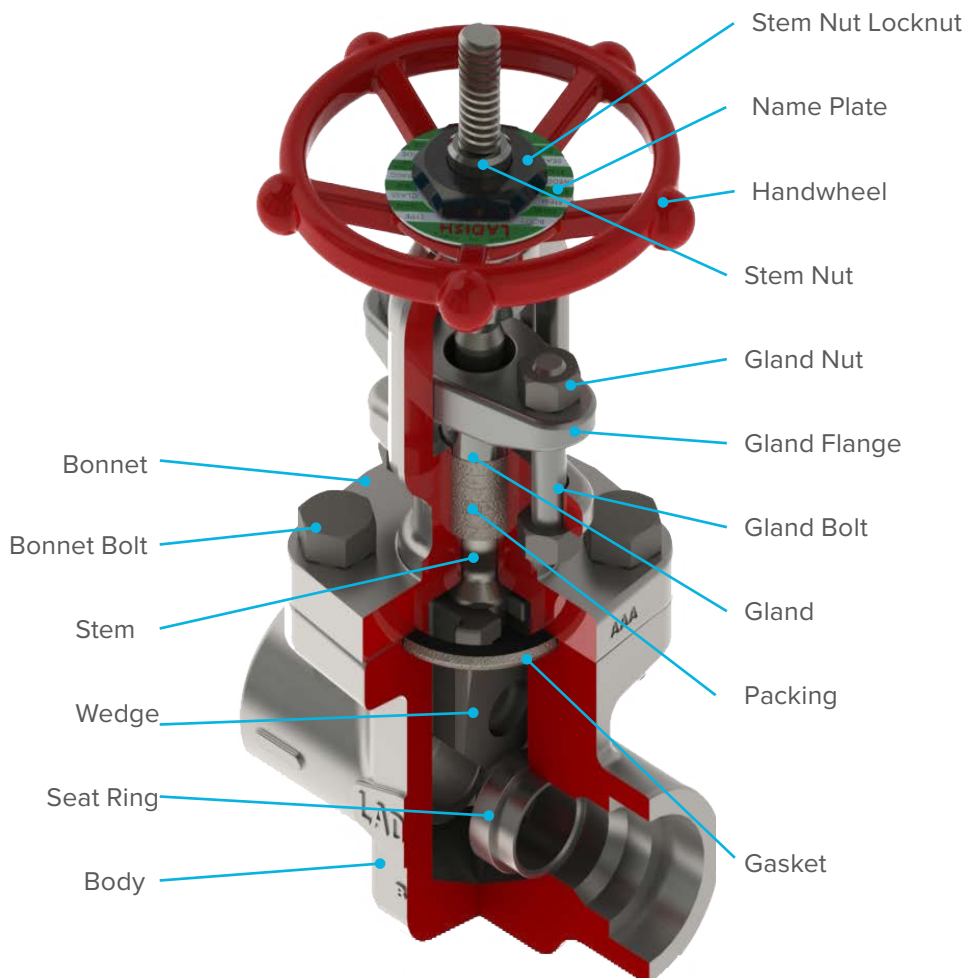

FORGED STEEL GATE VALVES

Dimensions

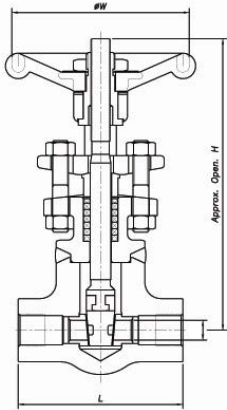

Welded bonnet (SWE,NPT,BWE)

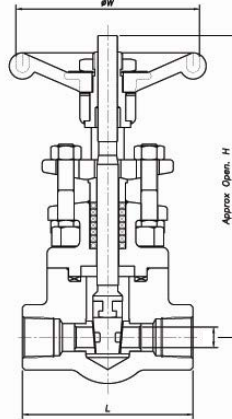

Bolted bonnet (SWE,NPT,BWE)

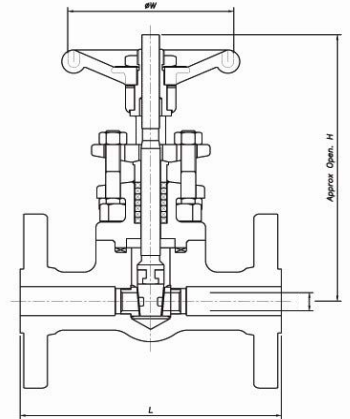

Bolted bonnet (Integral Flange)

SOCKET WELD, THREADED, BUTT WELD END

CLASS 800							
REDUCED PORT	DIM / SIZE	1/2"	3/4"	1"	1 1/4"	1 1/2"	2"
END TO END	L	3.27	3.39	4.17	4.74	4.74	5.35
HANDWHEEL	Ø W	3.54	3.54	3.54	4.72	4.72	5.51
OPEN	H	6.30	6.50	7.28	8.86	9.06	11.02
WEIGHT	LBS	4	5	7	10	12	21

CLASS 800							
FULL PORT	DIM / SIZE	1/2"	3/4"	1"	1 1/4"	1 1/2"	2"
END TO END	L	3.39	4.17	4.74	4.74	5.35	5.71
HANDWHEEL	Ø W	3.54	3.54	4.72	4.72	5.51	5.51
OPEN	H	6.50	7.28	8.86	9.06	11.02	12.40
WEIGHT	LBS	5	7	10	12	21	23

CLASS 1500							
REDUCED PORT	DIM / SIZE	1/2"	3/4"	1"	1 1/4"	1 1/2"	2"
END TO END	L	3.39	4.17	4.74	4.74	5.35	6.26
HANDWHEEL	Ø W	3.54	3.54	4.72	4.72	5.51	5.51
OPEN	H	6.69	7.28	9.06	11.22	11.42	11.81
WEIGHT	LBS	6	8	16	14	23	31

CLASS 1500							
FULL PORT	DIM / SIZE	1/2"	3/4"	1"	1 1/4"	1 1/2"	2"
END TO END	L	4.17	4.74	4.74	5.35	6.26	-
HANDWHEEL	Ø W	3.54	4.72	4.72	5.51	5.51	-
OPEN	H	7.28	9.06	11.22	11.42	11.81	-
WEIGHT	LBS	8	16	14	23	31	-

FLANGED TYPE

CLASS 150							
REDUCED PORT	DIM / SIZE	1/2"	3/4"	1"	1 1/4"	1 1/2"	2"
END TO END	L	4.25	4.61	5.00	-	6.50	7.01
HANDWHEEL	Ø W	3.54	3.54	3.54	-	4.72	5.51
OPEN	H	6.30	6.50	7.28	-	9.06	11.02
WEIGHT	LBS	6	9	10	-	18	34

CLASS 300							
REDUCED PORT	DIM / SIZE	1/2"	3/4"	1"	1 1/4"	1 1/2"	2"
END TO END	L	5.51	5.98	6.50	-	7.50	8.50
HANDWHEEL	Ø W	3.54	3.54	3.54	-	4.72	5.51
OPEN	H	6.30	6.50	7.28	-	9.06	11.02
WEIGHT	LBS	8	10	14	-	26	36

CLASS 600							
REDUCED PORT	DIM / SIZE	1/2"	3/4"	1"	1 1/4"	1 1/2"	2"
END TO END	L	6.50	7.48	8.50	-	9.49	11.50
HANDWHEEL	Ø W	3.54	3.54	3.54	-	4.72	5.51
OPEN	H	6.30	6.50	7.28	-	9.06	11.02
WEIGHT	LBS	8	12	15	-	31	44

CLASS 1500							
REDUCED PORT	DIM / SIZE	1/2"	3/4"	1"	1 1/4"	1 1/2"	2"
END TO END	L	8.50	9.02	10.00	-	12.01	14.49
HANDWHEEL	Ø W	3.54	3.54	4.72	-	5.51	5.51
OPEN	H	6.50	7.28	8.86	-	11.02	12.40
WEIGHT	LBS	19	23	30	-	88	100

Butt weld dimensions available upon request

FORGED STEEL GATE VALVES TAKEOFF AND INTEGRAL REINFORCED EXTENDED BODY (IREB) VALVE

- API 602, ASME B16.34
- Bolted and welded bonnet available
- Rising, non-rotating stem
- Outside screw and yoke (OS&Y)
- Hard facing on seating surfaces available.
- Bolted body-bonnet joint fully enclosed gasket design, both on ID and OD.
- Welded body-bonnet joint connection full strength weld.
- Nameplate serialization for full traceability.
- Packing API 622 and API 624 qualified packing for low fugitive emissions.

IREB

TAKEOFF VALVE

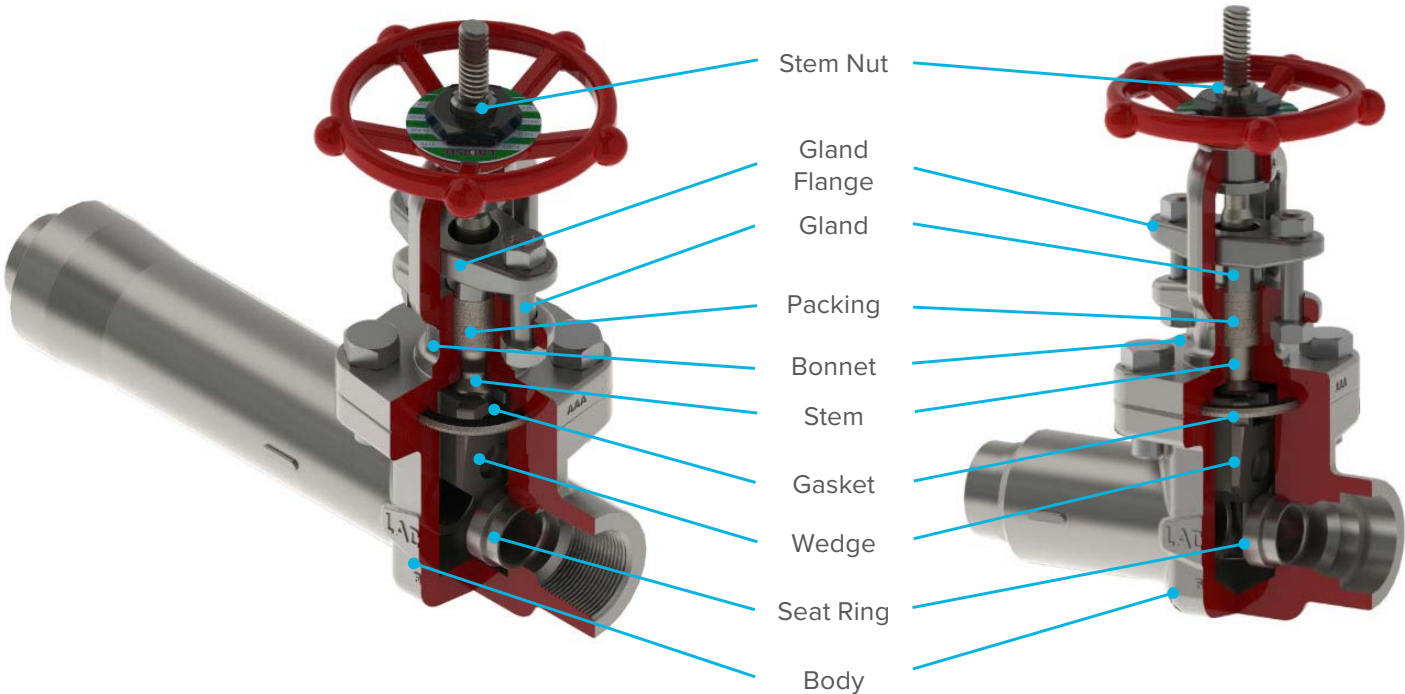

FORGED STEEL GATE VALVES TAKEOFF AND IREB VALVE

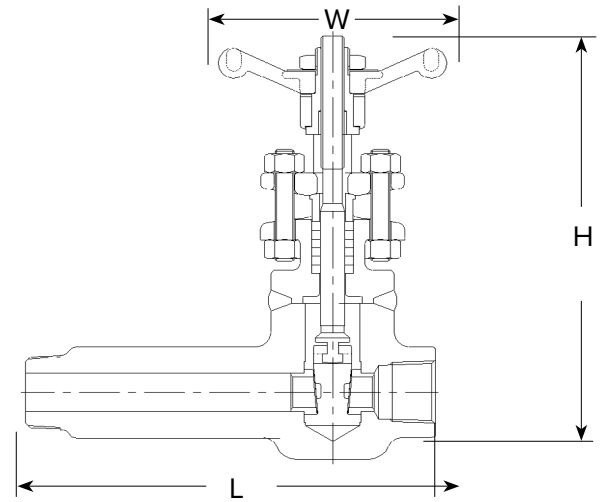
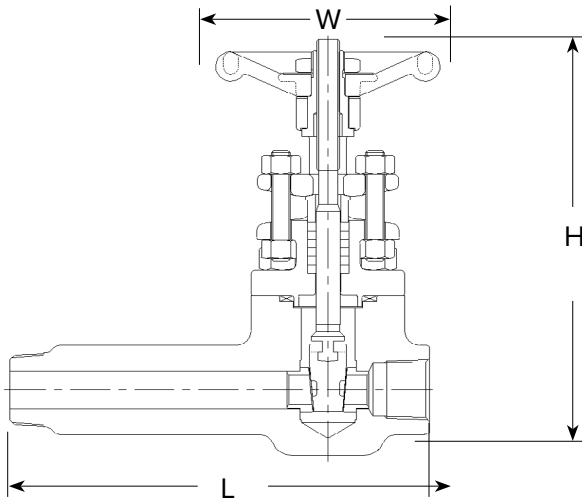

TAKE OFF

BOLTED BONNET

		CLASS 800				
REDUCED PORT	DIM / SIZE	1/2"	3/4"	1"	1 1/2"	2"
END TO END	L	5.63	5.75	5.94	7.13	7.72
HANDWHEEL	W	3.54	3.54	3.54	4.72	5.51
OPEN	H	6.30	6.50	7.28	9.06	11.02
WEIGHT	LBS	4	5	7	10	13

WELDED BONNET

		CLASS 800				
REDUCED PORT	DIM / SIZE	1/2"	3/4"	1"	1 1/2"	2"
END TO END	L	5.63	5.75	5.94	7.13	7.72
HANDWHEEL	W	3.54	3.54	3.54	4.72	5.51
OPEN	H	6.30	6.50	7.28	9.06	11.02
WEIGHT	LBS	4	4	6	11	17

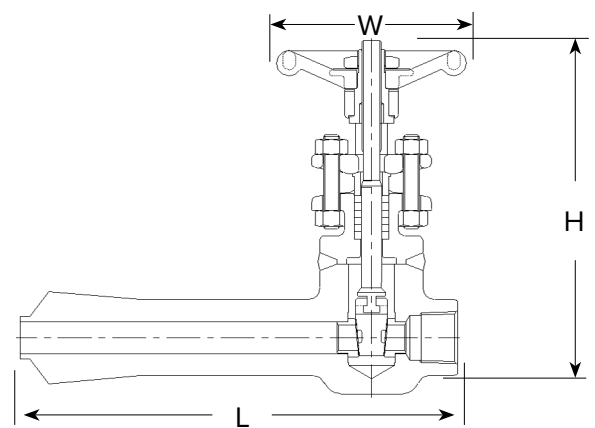
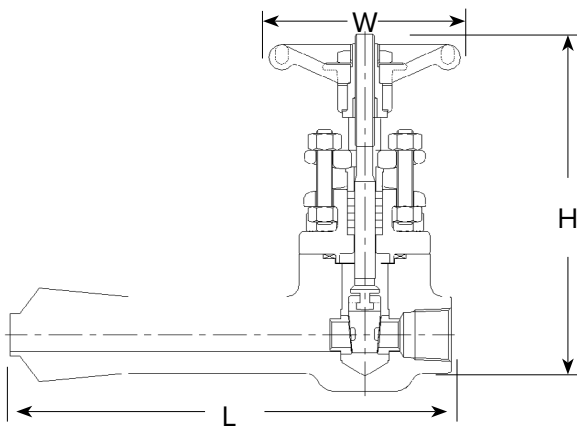

INTEGRALLY REINFORCED EXTENDED BONNET (IREB)

BOLTED BONNET

		CLASS 800				
REDUCED PORT	DIM / SIZE	1/2"	3/4"	1"	1 1/2"	2"
END TO END	L	8.15	8.62	9.57	10.37	10.53
HANDWHEEL	W	3.54	3.54	3.54	4.72	4.72
OPEN	H	6.30	6.50	7.28	9.06	11.02
WEIGHT	LBS	6	7	11	20	28

WELDED BONNET

		CLASS 800				
REDUCED PORT	DIM / SIZE	1/2"	3/4"	1"	1 1/2"	2"
END TO END	L	8.15	8.62	9.57	10.37	10.53
HANDWHEEL	W	3.54	3.54	3.54	4.72	4.72
OPEN	H	6.30	6.50	7.28	9.06	11.02
WEIGHT	LBS	5	7	10	19	27

FORGED STEEL GLOBE VALVES

Design & Construction

- API 602, ASME B16.34
- Bolted and welded bonnet available
- Full and reduced port available
- Threaded, socket weld, butt weld ends class 800 and 1500
- Flanged ends class 150 to class 1500
- Rising, non-rotating stem on select design.
- Outside screw and yoke (OS&Y)
- Hard facing on seating surfaces available.
- Bolted body-bonnet joint fully enclosed gasket design, both on ID and OD, allows for leak tight design.
- Welded body-bonnet joint connection full strength weld.
- Plug disc solid disc design constructed in forged or investment cast steel.
- Nameplate serialization for full traceability.
- Packing API 622 and API 624 qualified packing for low fugitive emissions.

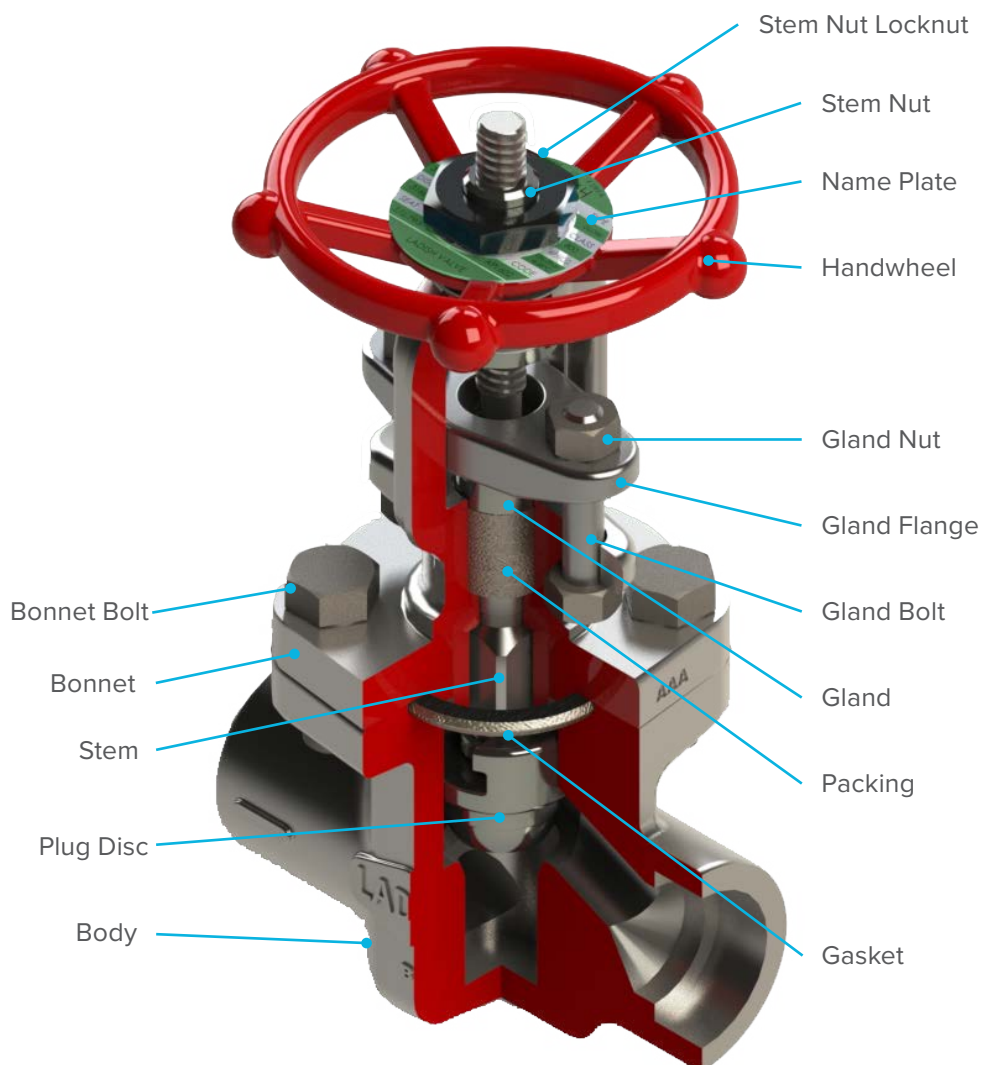

FORGED STEEL GLOBE VALVES

Dimensions

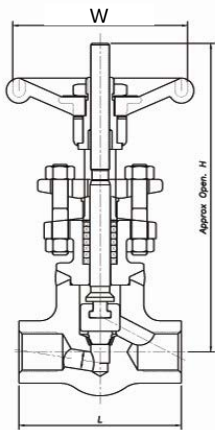

Welded bonnet (SWE,NPT,BWE)

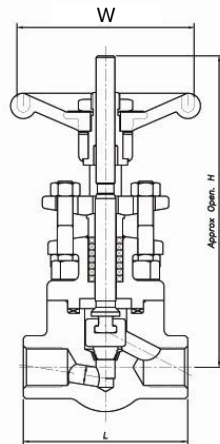

Bolted bonnet (SWE,NPT,BWE)

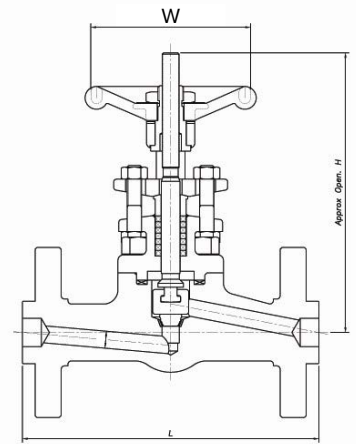

Bolted bonnet (Integral Flange)

SOCKET WELD, THREADED, BUTT WELD END

CLASS 800							
REDUCED PORT	DIM / SIZE	1/2"	3/4"	1"	1 1/4"	1 1/2"	2"
END TO END	L	3.27	3.39	4.17	5.94	5.94	6.73
HANDWHEEL	Ø W	3.54	3.54	3.54	4.72	4.72	5.51
OPEN	H	6.10	6.50	7.28	8.07	8.07	10.04
WEIGHT	LBS	4	5	7	13	13	25

CLASS 800							
FULL PORT	DIM / SIZE	1/2"	3/4"	1"	1 1/4"	1 1/2"	2"
END TO END	L	3.39	4.17	5.94	5.94	6.73	8.66
HANDWHEEL	Ø W	3.54	3.54	4.72	4.72	5.51	5.51
OPEN	H	6.50	7.28	8.07	8.07	10.04	11.81
WEIGHT	LBS	5	7	13	13	25	29

CLASS 1500							
REDUCED PORT	DIM / SIZE	1/2"	3/4"	1"	1 1/4"	1 1/2"	2"
END TO END	L	3.39	4.17	5.94	5.94	6.73	8.66
HANDWHEEL	Ø W	3.54	3.54	4.72	4.72	5.51	5.51
OPEN	H	6.69	7.28	7.87	7.87	9.84	11.42
WEIGHT	LBS	6	8	16	15	25	33

CLASS 1500							
FULL PORT	DIM / SIZE	1/2"	3/4"	1"	1 1/4"	1 1/2"	2"
END TO END	L	4.17	5.94	5.94	6.73	8.66	–
HANDWHEEL	Ø W	3.54	4.72	4.72	5.51	5.51	–
OPEN	H	7.28	7.87	7.87	9.84	11.42	–
WEIGHT	LBS	8	16	15	25	33	–

FLANGED TYPE

CLASS 150						
REDUCED PORT	DIM / SIZE	1/2"	3/4"	1"	1 1/2"	2"
END TO END	L	4.25	4.61	5.00	6.50	7.99
HANDWHEEL	Ø W	3.54	3.54	3.54	4.72	5.51
OPEN	H	6.10	6.10	7.28	8.07	10.04
WEIGHT	LBS	7	7	11	21	39

CLASS 300						
REDUCED PORT	DIM / SIZE	1/2"	3/4"	1"	1 1/2"	2"
END TO END	L	5.98	7.01	7.99	9.02	10.51
HANDWHEEL	Ø W	3.54	3.54	3.54	4.72	5.51
OPEN	H	6.10	6.50	7.28	8.07	10.04
WEIGHT	LBS	7	11	15	31	41

CLASS 600						
REDUCED PORT	DIM / SIZE	1/2"	3/4"	1"	1 1/2"	2"
END TO END	L	6.50	7.48	8.50	9.49	11.50
HANDWHEEL	Ø W	3.54	3.54	3.54	4.72	5.51
OPEN	H	6.10	6.50	7.28	8.07	10.04
WEIGHT	LBS	8	12	15	32	47

CLASS 900 – 1500						
REDUCED PORT	DIM / SIZE	1/2"	3/4"	1"	1 1/2"	2"
END TO END	L	8.50	9.02	10.00	12.01	14.49
HANDWHEEL	Ø W	3.54	3.54	4.72	5.51	5.51
OPEN	H	6.50	7.28	8.07	10.04	11.81
WEIGHT	LBS	18	23	30	89	101

Butt weld dimensions available upon request

FORGED STEEL CHECK VALVES

Design & Construction

- API 602, ASME B16.34
- Tested in accordance to API 598, ASME B16.34
- Hard faced seating surfaces available
- Threaded, socket weld and butt weld ends class 800-1500
- Flanged ends available for class 150 thru 1500
- Body / Cover Constructed of forged steel designed to API 602 and ASME B16.34.
- Body-Bonnet Joint Fully enclosed gasket design
- Lift check design is offered as either a piston check or ball check.
- Spring Available upon request.

SWING CHECK

LIFT CHECK

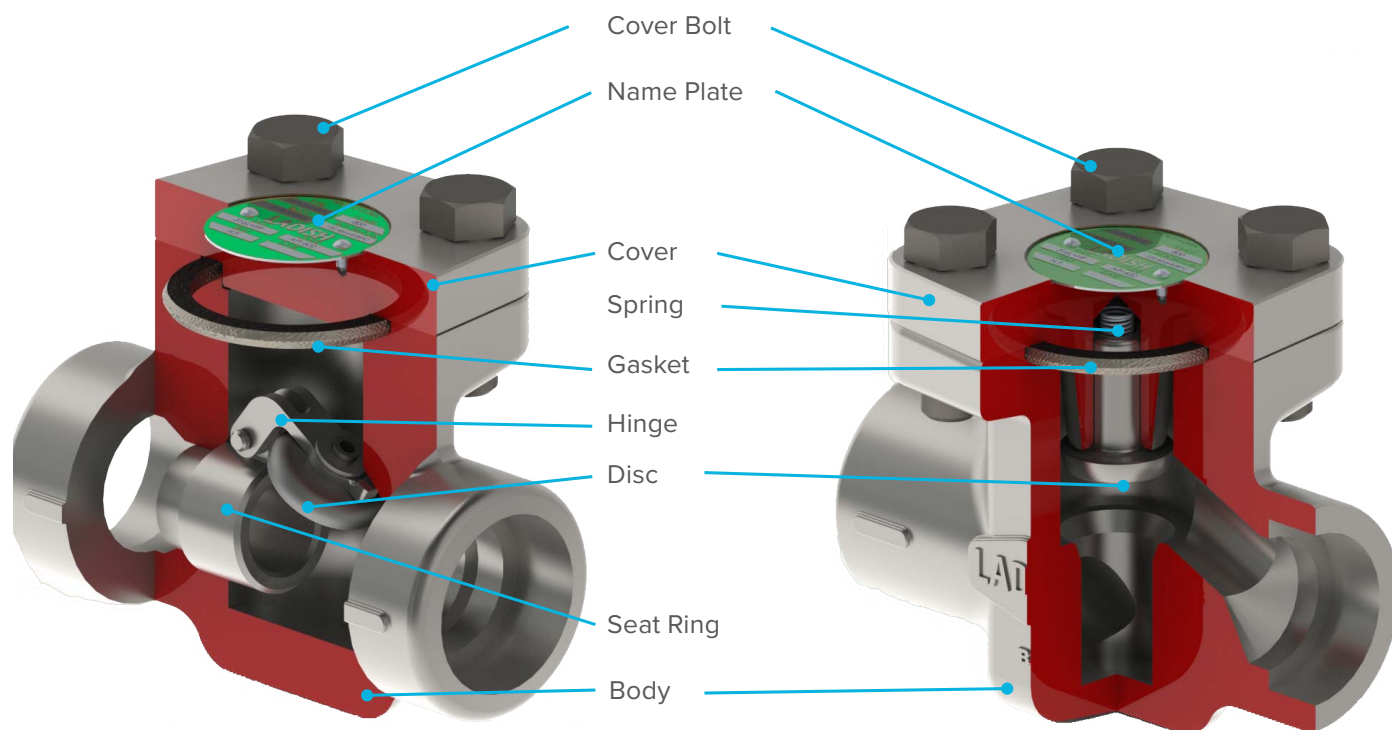

FORGED STEEL CHECK VALVES

Dimensions

SWING CHECK

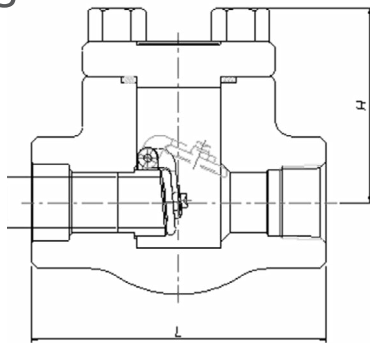

LIFT CHECK

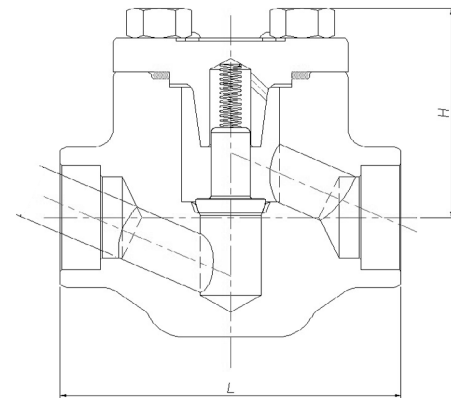

SOCKET WELD, THREADED, BUTT WELD END

SWING CHECK CLASS 800							
REDUCED PORT	DIM/SIZE	1/2"	3/4"	1"	1 1/4"	1 1/2"	2"
END TO END	L	3.27	3.39	4.17	4.76	4.76	5.35
CENTER-TOP	H	2.17	2.36	2.76	3.94	3.94	4.53
WEIGHT	LBS	2	2	4	8	9	13

SWING CHECK CLASS 1500							
REDUCED PORT	DIM/SIZE	1/2"	3/4"	1"	1 1/4"	1 1/2"	2"
END TO END	L	3.39	4.17	4.76	4.76	5.35	5.71
CENTER-TOP	H	2.36	2.76	3.94	3.94	4.53	5.51
WEIGHT	LBS	4	6	12	11	17	24

LIFT CHECK CLASS 800							
REDUCED PORT	DIM/SIZE	1/2"	3/4"	1"	1 1/4"	1 1/2"	2"
END TO END	L	3.27	3.39	4.17	5.94	5.94	6.73
CENTER-TOP	H	2.17	2.36	2.76	3.15	3.15	3.94
WEIGHT	LBS	2	4	6	11	11	18

LIFT CHECK CLASS 1500							
REDUCED PORT	DIM/SIZE	1/2"	3/4"	1"	1 1/4"	1 1/2"	2"
END TO END	L	3.39	4.17	5.94	5.94	6.73	8.66
CENTER-TOP	H	2.36	2.76	3.15	3.15	3.94	4.92
WEIGHT	LBS	4	6	14	12	19	26

FLANGED TYPE

SWING CHECK CLASS 150							
REDUCED PORT	DIM/SIZE	1/2"	3/4"	1"	1 1/2"	2"	
END TO END	L	4.25	4.61	5.00	6.50	7.99	
CENTER-TOP	H	2.17	2.36	2.76	3.94	4.53	
WEIGHT	LBS	5	7	10	16	24	

SWING CHECK CLASS 300							
REDUCED	DIM/SIZE	1/2"	3/4"	1"	1 1/2"	2"	
END TO END	L	5.98	7.01	7.99	9.02	10.51	
CENTER-TOP	H	2.17	2.36	2.76	3.94	4.53	
WEIGHT	LBS	7	11	14	28	36	

SWING CHECK CLASS 600							
REDUCED PORT	DIM/SIZE	1/2"	3/4"	1"	1 1/2"	2"	
END TO END	L	6.50	7.48	8.50	9.49	11.50	
CENTER-TOP	H	2.17	2.36	2.76	3.94	4.53	
WEIGHT	LBS	7	12	14	28	43	

SWING CHECK CLASS 900 – 1500							
REDUCED PORT	DIM/SIZE	1/2"	3/4"	1"	1 1/2"	2"	
END TO END	L	8.50	9.02	10.00	12.01	14.49	
CENTER-TOP	H	2.36	2.76	3.94	4.53	4.92	
WEIGHT	LBS	10	16	23	36	63	

LIFT CHECK CLASS 150							
REDUCED PORT	DIM/SIZE	1/2"	3/4"	1"	1 1/2"	2"	
END TO END	L	4.25	4.61	5.00	6.50	7.99	
CENTER-TOP	H	2.17	2.36	2.76	3.15	3.94	
WEIGHT	LBS	5	6	9	18	25	

LIFT CHECK CLASS 300							
REDUCED PORT	DIM/SIZE	1/2"	3/4"	1"	1 1/2"	2"	
END TO END	L	5.98	7.01	7.99	9.02	10.51	
CENTER-TOP	H	2.17	2.36	2.76	3.15	3.94	
WEIGHT	LBS	6	10	13	29	37	

LIFT CHECK CLASS 600							
REDUCED PORT	DIM/SIZE	1/2"	3/4"	1"	1 1/2"	2"	
END TO END	L	6.50	7.48	8.50	9.49	11.50	
CENTER-TOP	H	2.17	2.36	2.76	3.15	3.94	
WEIGHT	LBS	6	11	14	29	37	

LIFT CHECK CLASS 900 – 1500							
REDUCED PORT	DIM/SIZE	1/2"	3/4"	1"	1 1/2"	2"	
END TO END	L	8.50	9.02	10.00	12.01	14.49	
CENTER-TOP	H	2.36	2.76	3.15	3.94	4.53	
WEIGHT	LBS	9	15	21	28	43	

Butt weld dimensions available upon request

BELLOWS SEAL GATE VALVES

Design & Construction

- Zero emissions
- Helium leak testing
- Low emissions secondary sealing
- Graphite gland packing
- Integral backseat
- Full strength weld
- Welded or bolted bonnet type
- Seat and wedge stellite faced

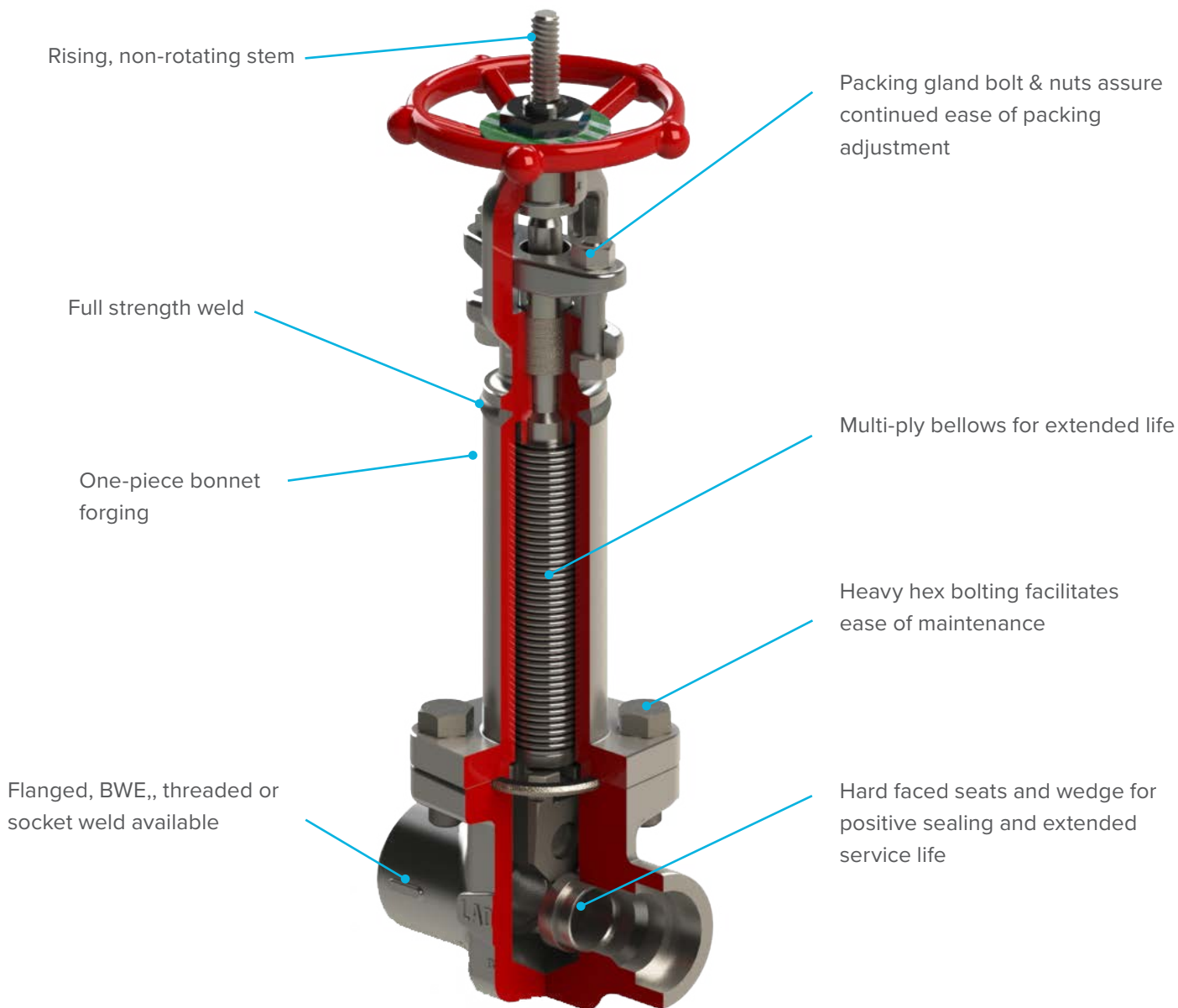

BELLOWS SEAL GATE VALVES

Exploded View

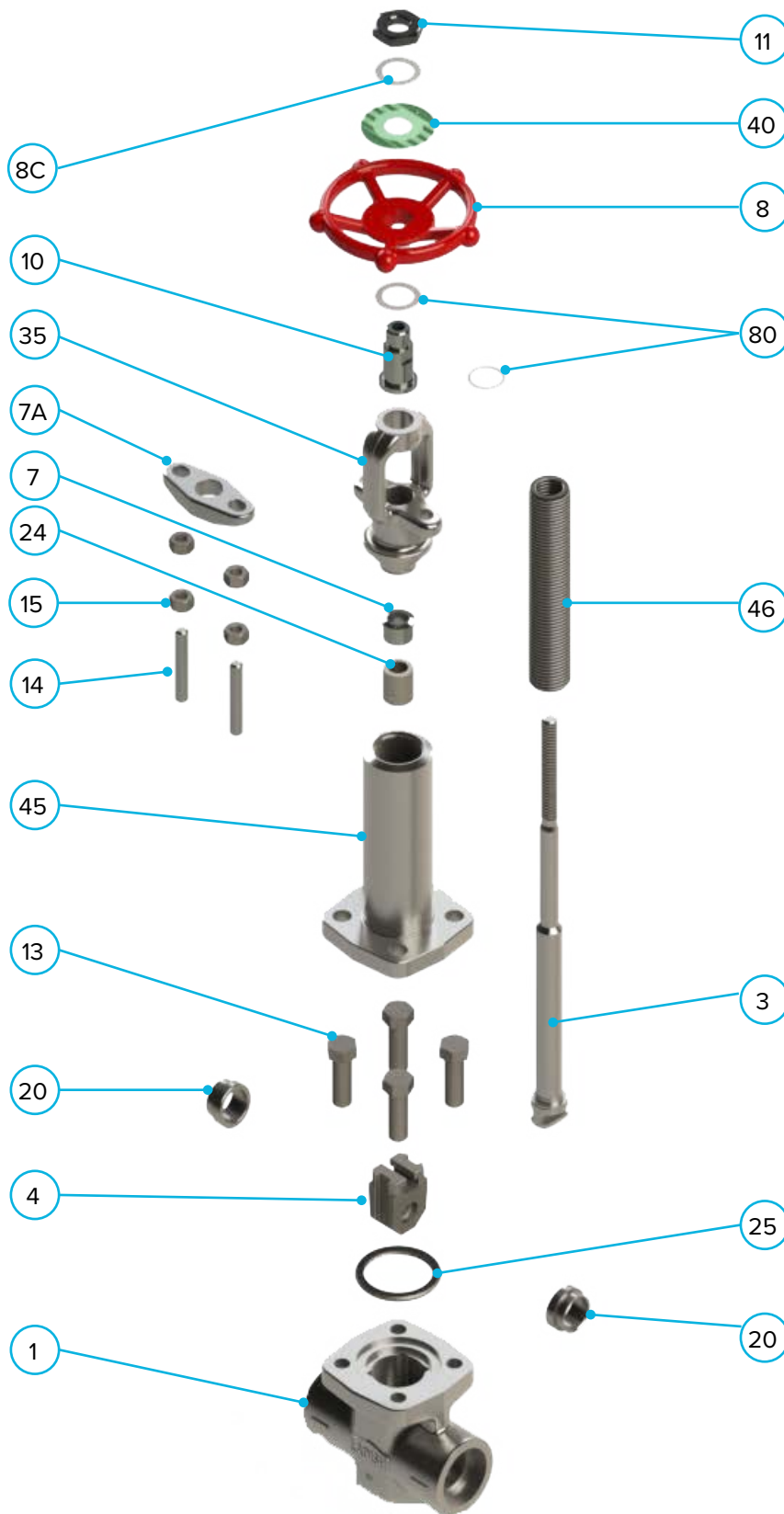

1	Body
3	Stem
4	Wedge
7	Gland
7A	Gland Flange
8	Handwheel
8C	Handwheel Washer
10	Stem Nut
11	Stem Nut Locknut
13	Body Bolt/Stud
14	Gland Stud
15	Gland Nut
20	Seat Ring
24	Packing
25	Gasket
35	Yoke
40	Name plate
45	Extension
46	Bellows
80	Stem Nut Washer

BELLOWS SEAL GLOBE VALVES

Design & Construction

- Zero emissions
- Helium leak testing
- Low emissions secondary sealing
- Graphite gland packing
- Integral backseat
- Full strength weld
- Welded or bolted bonnet type
- Seat and plug disc stellite faced

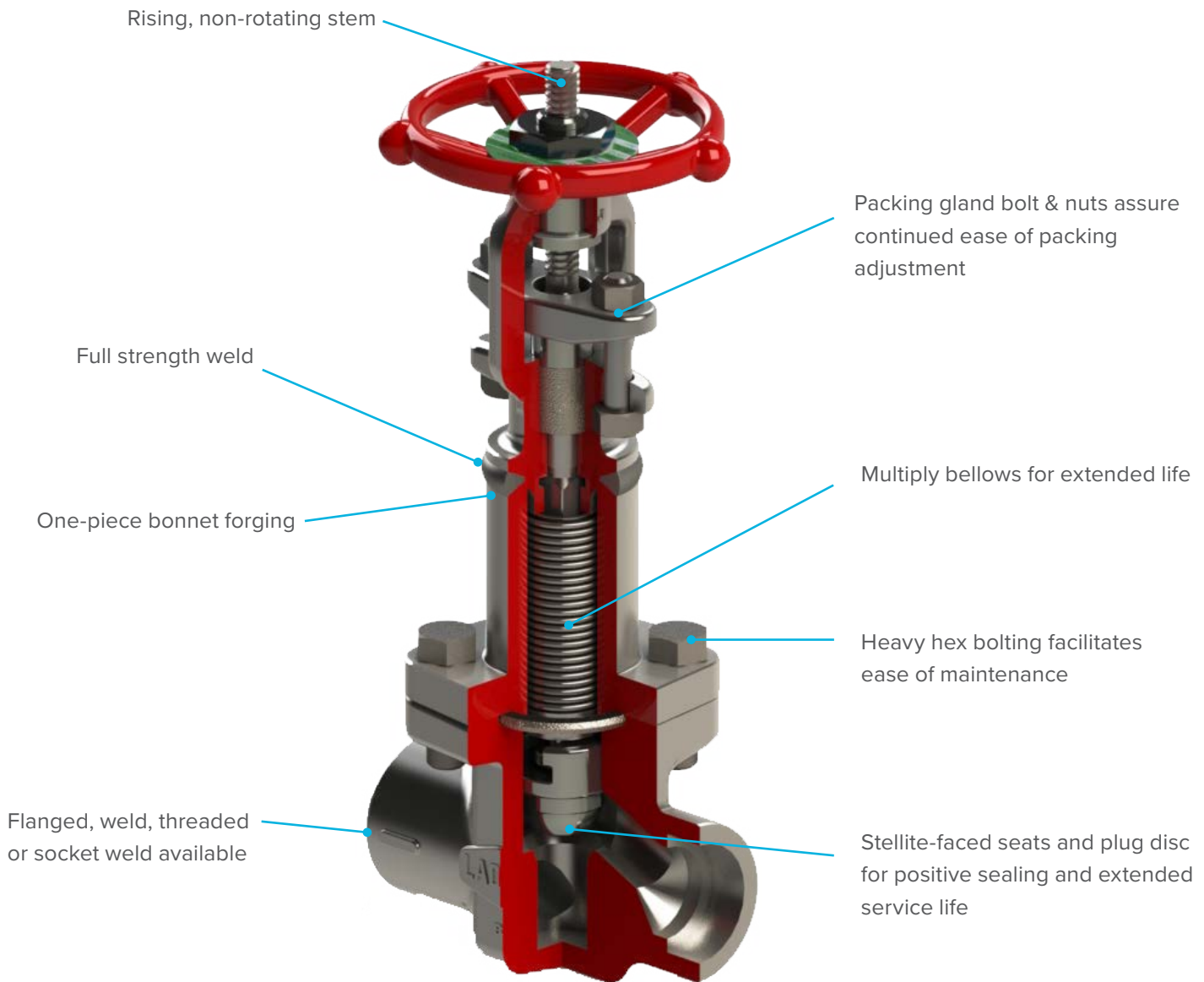

BELLOWS SEAL GLOBE VALVES

Exploded View

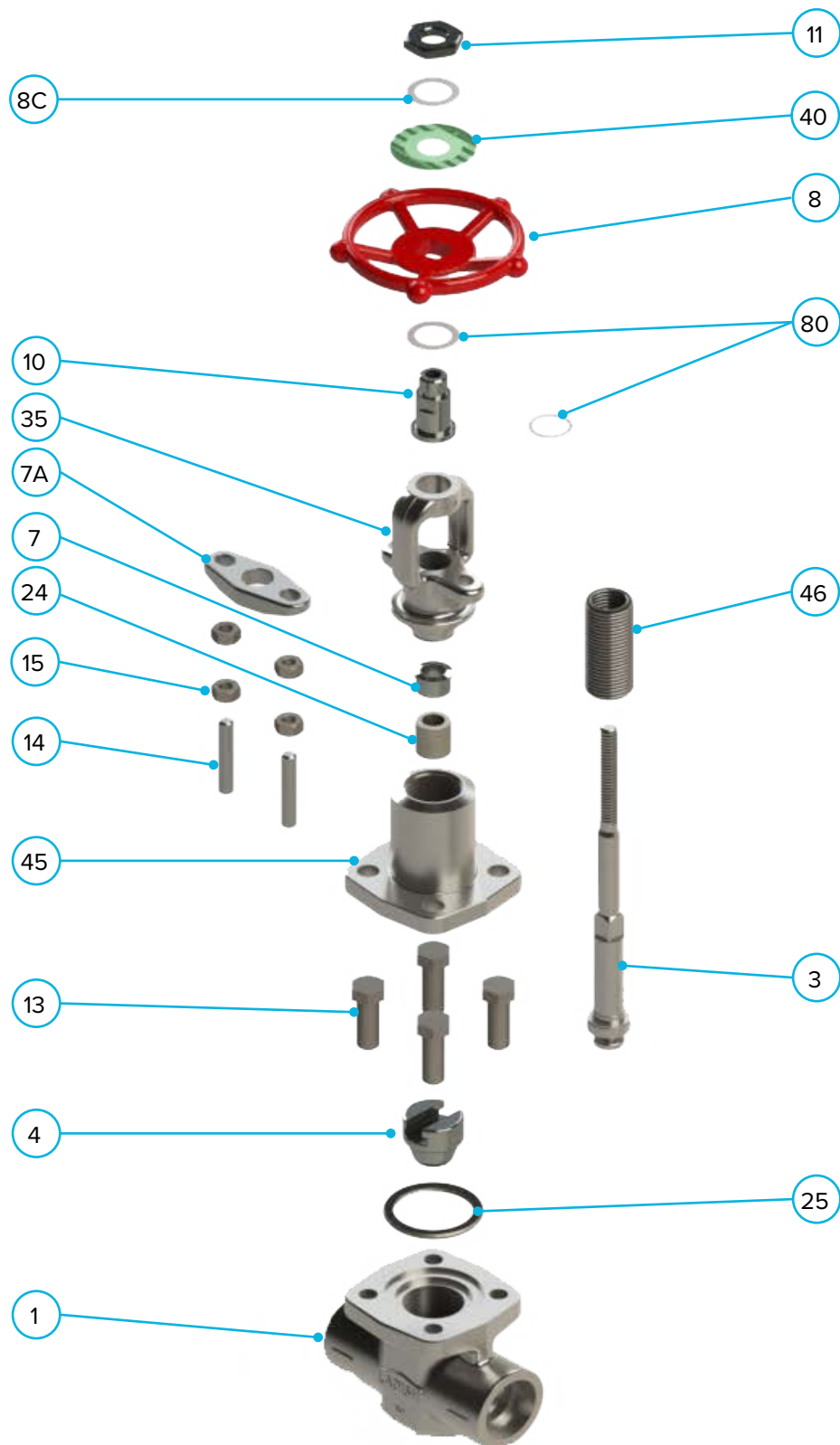

1	Body
3	Stem
4	Plug
7	Gland
7A	Gland Flange
8	Handwheel
8C	Handwheel Washer
10	Stem Nut
11	Stem Nut Locknut
13	Body Bolt/Stud
14	Gland Stud
15	Gland Nut
24	Packing
25	Gasket
35	Yoke
40	Name plate
45	Extension
46	Bellows
80	Stem Nut Washer

BELLOWS SEAL GATE VALVES

Dimensions

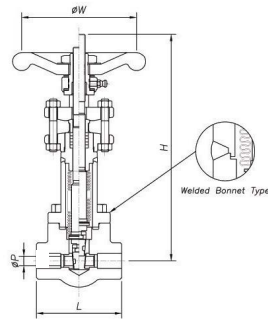

- CLASS: 800 & 1500
- SIZE: 1/2"-2"
- PORT: reduced / full
- END: NPT, SWE & BWE
- Bolted and welded bonnet connections available

SOCKET WELD THREADED

CLASS 800							
REDUCED PORT	DIM/SIZE	1/2"	3/4"	1"	1 1/4"	1 1/2"	2"
END TO END	L	3.27	3.39	4.17	4.76	4.76	5.35
HANDWHEEL	Ø W	3.54	3.54	3.54	4.72	4.72	5.51
OPEN	H	9.06	10.24	11.81	16.54	16.54	18.90
WEIGHT	LBS	8	8	10	17	17	28

CLASS 1500							
REDUCED PORT	DIM/SIZE	1/2"	3/4"	1"	1 1/4"	1 1/2"	2"
END TO END	L	3.39	4.17	4.76	4.76	5.35	5.71
HANDWHEEL	Ø W	3.54	3.54	4.72	4.72	5.51	5.51
OPEN	H	12.99	16.14	17.72	19.69	24.41	29.92
WEIGHT	LBS	11	12	22	37	37	50

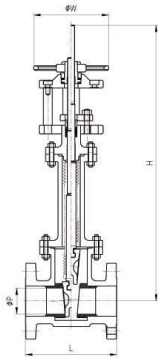

- CLASS: 150, 300, 600 & 1500
- SIZE: 1/2"-2"
- END: Integral Flange; FF, RF & RTJ
- Bolted and welded bonnet connections available

FLANGED TYPE

CLASS 150							
REDUCED PORT	DIM/SIZE	1/2"	3/4"	1"	1 1/4"	1 1/2"	2"
END TO END	L	4.25	4.61	5.00	-	6.50	7.01
HANDWHEEL	Ø W	3.54	3.54	3.54	-	4.72	5.51
OPEN	H	9.06	10.24	11.81	-	16.54	18.90
WEIGHT	LBS	10	11	14	-	23	41

CLASS 300							
REDUCED PORT	DIM/SIZE	1/2"	3/4"	1"	1 1/4"	1 1/2"	2"
END TO END	L	5.51	5.98	6.50	-	7.52	8.50
HANDWHEEL	Ø W	3.54	3.54	3.54	-	4.72	5.51
OPEN	H	9.06	10.24	11.81	-	16.54	18.90
WEIGHT	LBS	11	13	17	-	30	44

CLASS 600							
REDUCED PORT	DIM/SIZE	1/2"	3/4"	1"	1 1/4"	1 1/2"	2"
END TO END	L	6.50	7.48	8.50	-	9.49	11.50
HANDWHEEL	Ø W	3.54	3.54	3.54	-	4.72	5.51
OPEN	H	9.06	10.24	11.81	-	16.54	18.90
WEIGHT	LBS	11	14	19	-	36	53

CLASS 1500							
REDUCED PORT	DIM/SIZE	1/2"	3/4"	1"	1 1/4"	1 1/2"	2"
END TO END	L	8.50	9.02	10.00	-	12.01	14.49
HANDWHEEL	Ø W	3.54	3.54	4.72	-	5.51	5.51
OPEN	H	12.99	16.14	17.72	-	24.41	29.92
WEIGHT	LBS	24.0	26.9	36.4	-	101.4	115.8

Full port dimensions available upon request

BELLOWS SEAL GLOBE VALVES

Dimensions

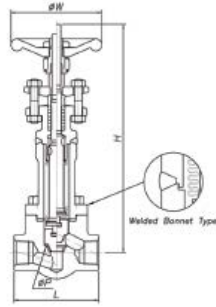

- Class 800 – 1500
- SIZE – 1/2" – 2"
- END – NPT, SWE, BWE
- Port – reduced/full
- Bolted and welded bonnet connections available

SOCKET WELD THREADED

CLASS 800							
REDUCED PORT	DIM/SIZE	1/2"	3/4"	1"	1 1/4"	1 1/2"	2"
END TO END	L	3.27	3.39	4.17	5.94	5.94	6.73
HANDWHEEL	Ø W	3.54	3.54	3.54	4.72	4.72	5.51
OPEN	H	9.45	9.45	9.65	12.40	12.40	16.34
WEIGHT	LBS	6	7	9	17	17	30

CLASS 1500							
REDUCED PORT	DIM/SIZE	1/2"	3/4"	1"	1 1/4"	1 1/2"	2"
END TO END	L	3.39	4.17	5.94	5.94	6.73	5.51
HANDWHEEL	Ø W	3.54	3.54	4.72	4.72	5.51	–
OPEN	H	9.45	9.45	12.60	16.54	18.11	–
WEIGHT	LBS	8	10	19	31	31	–

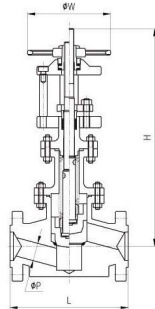

- CLASS-150, 300, 600 & 1500
- SIZE – 1/2" – 2"
- END – Integral Flange; FF, RF, RTJ
- Bolted and welded bonnet connections available

FLANGED TYPE

CLASS 150						
REDUCED PORT	DIM/SIZE	1/2"	3/4"	1"	1 1/2"	2"
END TO END	L	4.25	4.61	5.00	6.50	7.99
HANDWHEEL	Ø W	3.54	3.54	3.54	4.72	5.51
OPEN	H	9.45	9.45	9.65	12.40	16.34
WEIGHT	LBS	9	9	13	25	35

CLASS 300						
REDUCED PORT	DIM/SIZE	1/2"	3/4"	1"	1 1/2"	2"
END TO END	L	5.98	7.01	7.99	9.02	10.51
HANDWHEEL	Ø W	3.54	3.54	3.54	4.72	5.51
OPEN	H	9.45	9.45	9.65	12.40	16.34
WEIGHT	LBS	10	12	17	34	45

CLASS 600						
REDUCED PORT	DIM/SIZE	1/2"	3/4"	1"	1 1/2"	2"
END TO END	L	6.50	7.48	8.50	9.49	11.50
HANDWHEEL	Ø W	3.54	3.54	3.54	4.72	5.51
OPEN	H	9.45	9.45	9.65	12.40	16.34
WEIGHT	LBS	10	13	17	35	50

CLASS 1500						
REDUCED PORT	DIM/SIZE	1/2"	3/4"	1"	1 1/2"	2"
END TO END	L	8.50	9.02	10.00	12.01	–
HANDWHEEL	Ø W	3.54	3.54	4.72	5.51	–
OPEN	H	9.45	9.45	12.60	18.11	–
WEIGHT	LBS	21	25	34	95	–

Full port dimensions available upon request

BELLOWS VALVES

Design Highlights

Microplasma welding of bellows

- Stem-bellows connection and yoke-bellows connection both microplasma welded

Cycle testing in accordance with API-602

- Bellows samples are extended and compressed at maximum working conditions until required cycle life is achieved
- 1 Cycle = Open to Close to Open

Minimum Cycle Life $\leq 2''$

● API 602 ● LADISH VALVES

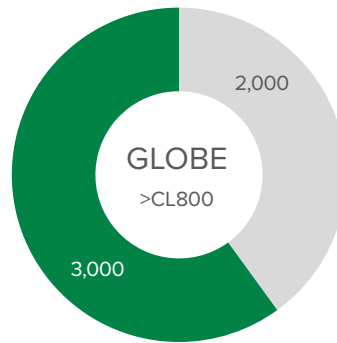
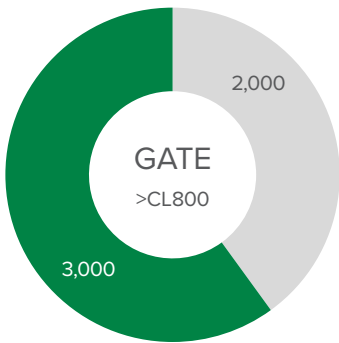
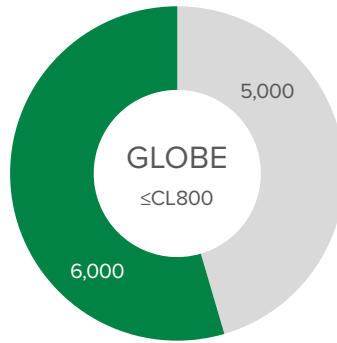
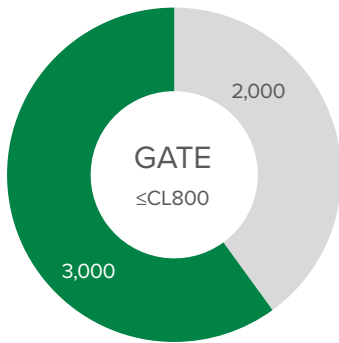

Post cycling penetrant test of bellows



Helium leak testing – instrument sensitivity $< 10^{-3} \text{ mm}^3/\text{s}$



Pressure testing of each valve



TO MARK PROGRESS

LADISH VALVES

Fugitive Emissions

Since the introduction of the U.S. Clean Air Act in 1963, the U.S. Environmental Protection Agency (EPA) and individual states have set increasingly stringent consent decrees for fugitive emissions from industrial facilities. Many companies have implemented Leak Detection and Repair (LDAR) programs, and industry groups have focused efforts on helping member companies decrease valve emissions.

Ladish Valves was one of the first companies to help in assisting companies, by testing our valves to meet or exceed low fugitive emission in our valves. Ladish Valves has successfully tested our product, to the following industries standards.

- API 624
- API 641
- ISO-15848-1
- TA-LUFT

Low Fugitive Emission seals require that each element of the sealing system is precisely manufactured for straightness, surface finish and concentricity.

Ladish Valves utilizes an API-622 approved inter-braided graphite packing as standard, with machine surface stem finishes of better than 32 Ra and stuffing box wall finishes to 125 Ra ensuring maximum sealing effectiveness.

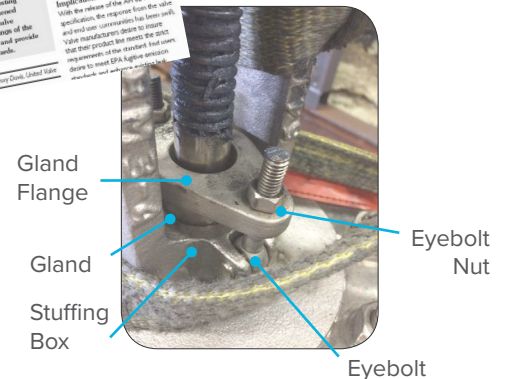
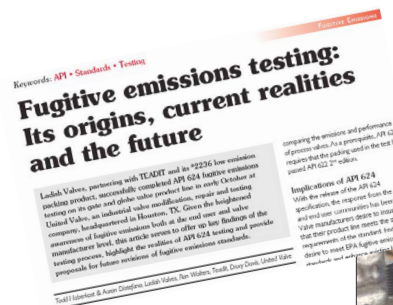

HOW TO ORDER

LADISH FORGED STEEL VALVES

Ladish Valves are identified by a 16-digit alpha-numeric code, detailed in the table below. Our aim is to accurately fill your order, so if you need assistance, please contact our knowledgeable sales staff at ☎281.880.8560. Provide us with the leading four digits and we can guide you through the rest.

EXAMPLE:

8863-6C06-CG04-A10 = 1" CL800 THD GATE B564 N10276 TR HHF GRF B8MCL2 RP

VALVE STYLE		CONSTRUCT & VALVE TYPE		END CONNECT & CLOSURE TYPE		DESIGN STANDARD
88		6		3		6
GATE Bolt Bonnet 82– CL150 83– CL300 86– CL600 88– CL800 89– CL900 85– CL1500 Weld Bonnet 87– CL800 81– CL1500 84– CL2500 GLOBE Bolt Bonnet 72– CL150 73– CL300 76– CL600 78– CL800 79– CL900 75– CL1500 Weld Bonnet 77– CL800 71– CL1500 74– CL2500	Y-GLOBE 62– CL150 63– CL300 66– CL600 68– CL800 69– CL900 65– CL1500 64– CL2500 CHECK Bolt Cover 52– CL150 53– CL300 56– CL600 58– CL800 59– CL900 55– CL1500 Weld Cover 57– CL800 51– CL1500 54– CL2500 Y-CHECK 32– CL150 33– CL300 36– CL600 38– CL800 39– CL900 35– CL1500 34– CL2500	GATE 2– Pressure Seal 4– Bellows Seal 6– OS&Y THD/ SWE (≥CL300) 7– OS&Y THD/ SWE/BWE (CL150) & RF/ BWE (ALL CL) 9– CRYO GLOBE 2– Pressure Seal 4– Bellows Seal 6– OS&Y THD/ SWE/BWE (≥CL300) 7– OS&Y THD/ SWE/BWE (CL150) & RF (ALL CL) 8– Angle 9– CRYO Y-GLOBE 2– Pressure Seal 4– Bellows Seal 6– OS&Y THD/ SWE/BWE (≥CL300) 7– OS&Y THD/ SWE/BWE (CL150) & RF (ALL CL) 9– CRYO	CHECK 2– Pressure Seal 3– Stop type 5– Lift type 7– Swing type 9– CRYO 4– Ball check Y-CHECK 2– Pressure Seal 3– Stop type 5– Lift type 7– Swing type 9– CRYO 4– Ball check	GATE 3 – THD, Solid 4 – SWE, Solid 5 – RF, Solid 9 – BWE, Solid 0 – THD, Split 1 – SWE, Split 2 – RF, Split 6 – BWE, Split 7 – THDxSWE, Solid 8 – Ext body (FTHxMP) 9 – BWE, Solid GLOBE 3 – THD, PTFE 4 – SWE, PTFE 5 – RF, PTFE 9 – BWE, PTFE 0 – THD, Metal 1 – SWE, Metal 2 – RF, Metal 6 – BWE, Metal 7 – THDxSWE, Metal 9 – BWE, PTFE Y-GLOBE 3 – THD, PTFE 4 – SWE, PTFE 5 – RF, PTFE 9 – BWE, PTFE 0 – THD, Plug 1 – SWE, Plug 2 – RF, Plug 6 – BWE, Plug 7 – THDxSWE, Plug 9 – BWE, PTFE	CHECK 3 – THD, PTFE 4 – SWE, PTFE 5 – RF, PTFE 9 – BWE, PTFE 0 – THD, Metal 1 – SWE, Metal 2 – RF, Metal 6 – BWE, Metal 7 – THDxSWE, Metal 9 – BWE, PTFE Y-CHECK 3 – THD, PTFE 4 – SWE, PTFE 5 – RF, PTFE 9 – BWE, PTFE 0 – THD, Metal 1 – SWE, Metal 2 – RF, Metal 6 – BWE, Metal 7 – THDxSWE, Metal 9 – BWE, PTFE	1 – API603 2 – API600 3 – B16.34 4 – API6D 5 – API608 6 – API602 7 – API594 8 – API623



MATERIAL	TRIM & PART	PACKING TYPE	GASKET TYPE	BOLTING & NUTS	MISC. OPTION	SIZE
C0	6	C	G	04	A	10
	1 – Std Trim Full Port 2 – Half Hard Full Port 3 – Full Hard Full Port 4 – Std Trim Red Port 5 – Half Hard Red Port 6 – Full Hard Red Port	A – N/A G – Teadit API 622 GRF P – Pillar API 622 GRF B – Generic GRF E – Garlock EVSP H – High Temp T – Teflon V-Ring F – Teflon Braided C – Garlock API 622 J – Chesterton API 622	A – N/A G – GRF H – HIGH TEMP T – PTFE R – METAL (RING JOINT)	00 – N/A 01 – B8CL1/8 02 – B8CL2/8 03 – B8MCL1/ 8M 04 – B8MCL2/ 8M 05 – B7/2H 06 – B7M/2HM 07 – ALLOY 20 08 – MONEL400 09 – GR660 10 – L7/7 11 – INC 800 12 – HAST C 13 – B6/6 14 – B16/16 15 – K500 16 – A320 B8CL2/8 17 – B8CL2/8A 18 – B16/7 20 – L7M/7M	A – N/A B – Clean G – Gear Op H – Flat Face J – RTJ K – Actuator L – Live Load M – Acid Shield O – IREBxTHD R – 100% RT S – Spring Load V – Vent Wedge W – Chain Wheel OP 1 – BWE S10 4 – BWE S40 5 – BWE S5 6 – BWE S160 8 – BWE S80 D – FTHDx MTHD	02 – 1/8" 03 – 3/8" 04 – 1/4" 05 – 1/2" 07 – 3/4" 10 – 1" 12 – 1 1/4" 15 – 1 1/2" 20 – 2" 22 – 2 1/2" 25 – 2 1/2" 30 – 3" 40 – 4"



MATERIALS OF CONSTRUCTION



A1 A182-F304	A6 A182-F316L	B4 A182-F309	D0 B564-N04400	F5 A182-F51	H2 A350 LF2 CL 1	H9 A182 F91
A2 A182-F304L	A7 A182-F316H	B5 B462-N08020	D3 B564-N06600	F6 A182-F53	J1 A182 F11 CL 2	MORE AVAILABLE UPON REQUEST
A3 A182-F304H	B0 A182-F317DC	B6 A182-F44	D4 B564-N06625	F7 A182-F55	J2 A182 F22	
A4 A182-F310	B1 A182-F317L	B8 A182-F321	D6 B564-N08825	F8 A182-F60	J5 A182 F5	
A5 A182-F316DC	B2 A182-F347H	C0 B564-N10276	F2 A182-F61	H0 A105	J9 A182 F9	

LADISH VALVES

CONTROLLED QUALITY • CORROSION RESISTANT



TO MARK PROGRESS

-  7603 Bluff Point Dr., Houston, TX 77086
-  281.880.8560
-  ladishvalves.com
-  sales@ladishvalves.com

Published technical data and general information are intended solely for the coverage of typical applications for users of Ladish Valves products featured in this catalog. Please contact Ladish Valves for specific questions, technical assistance, or to produce your own study, data and conclusions related to the quality and performance of our products to a specific application. Ladish Valves is not responsible for property damage and/or personal injury that may result from failure to follow these instructions. Any information listed in this brochure is subject to change with regard to time sensitivity, error correction, product and design introduction, modification or discontinuation, as well as any other changes Ladish Valves considers appropriate.