

"THE NEXT GENERATION"



**FLOW SAFE**

*High Performance Safety Relief Valves*



**F80 Series**  
*Spring-Operated Safety Valves  
for Gas Service*

# CONTENTS

<i>SECTION</i>	<i>PAGE</i>
Introduction and Features.....	2
Operation.....	3-5
Service Envelope.....	6-7
Seat Data.....	7
Dimensions & Weights.....	8-9
F84 Construction .....	10-11
F85 Construction .....	12-13
F88 Construction .....	14-15
Sizing and Capacities .....	16-25
Part Numbering.....	26
How to Order .....	27
Other Flow Safe Products.....	Back Cover

The policy of FLOW SAFE and its authorized assemblers is a commitment to value through:

- Environmentally compatible products
- Cost-efficient design with minimal parts
- Quality products, readily available
- Flexibility to meet unique customer needs
- “No-hassle” service

# INTRODUCTION AND FEATURES

Today’s industrial needs are being driven by requirements for high-capacity leak-tight pressure relief valves to reduce fugitive emissions and to save customer product.

The **F80** Series “High Performance” spring-operated safety valves are engineered to provide superior performance for today’s industries.

**F80** design features include:

- ASME-UV stamp standard at 15 psig (1.03 barg) and above; ‘CE’ Mark available
- National Board-certified for gas service per ASME Section VIII
- Full lift at set pressure
- Full open until reseal
- Adjustable blowdown feature on F84, F85
- Repeatable, bubble-tight seating and re-seating due to soft seat design
- Superior capacities through large nozzles
- Set pressures to 10,313 psig (711 barg)
- -423 to 525 °F (-252 to 274 °C) temperature range
- Standard brass or 316 SS construction; special materials available
- NPT inlet & outlet standard; flanges, hubs, SAE & AS5202 threads, or other special connections available
- Integral nozzle / inlet bushing
- Packed lift levers available on most sizes

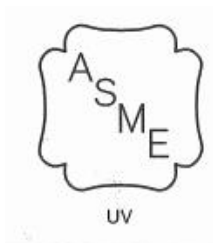

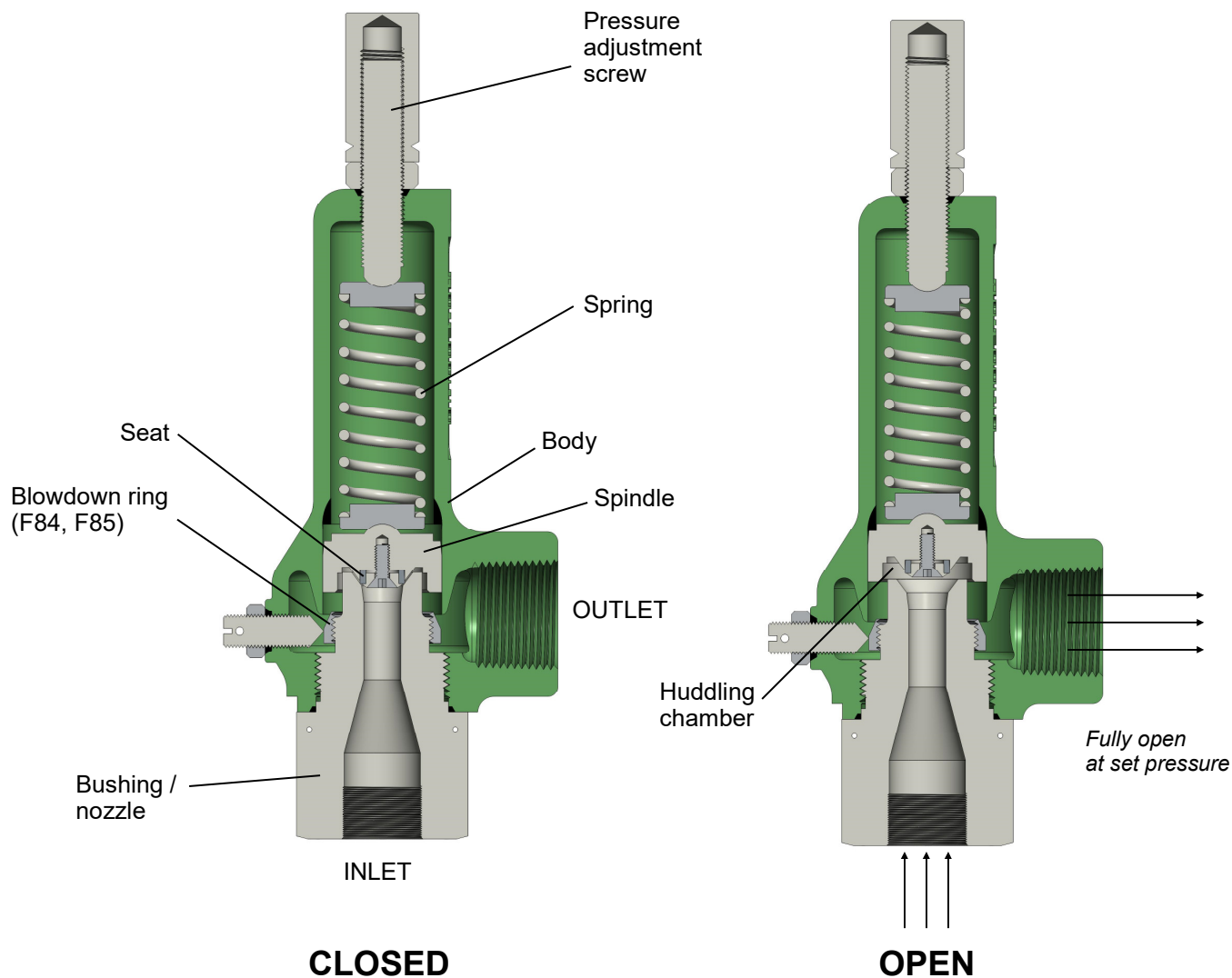

In any pressurized system, there is the potential for a pressure rise that could damage the vessel or piping and create a hazard to bystanders. A pressure relief valve is recognized as the critical safety device that limits this rise by venting excess pressure from the system.

The Flow Safe **F80** Series safety valves are high-performance state-of-the-art, cost-efficient, high capacity, soft-seated valves designed to meet the critical needs of today's industry. This series includes Models F84 (plastic seat) and F85 (O-ring seat), with a pressurized spring chamber and unbalanced against backpressure, and Model F88 (plastic seat), with an open spring chamber and balanced against backpressure.

Bubble-tight shutoff is achieved through the use of an elastomeric (F85) or plastic (F84 and F88) seat. The F80's use a compression spring that opposes system inlet pressure acting on the valve's effective seat area ( $F = P \times A$ ), to establish the set pressure. When system pressure overcomes the spring preload, an initial escape of fluid called "simmer" occurs past the seat. As simmer continues, there is a significant pressure buildup within the huddling chamber that eventually forces the valve to pop open.

In the F84 and F85, the blowdown ring acts along with the body bore to create a restriction in the flow-path to the valve outlet. Pressure also flows between the spindle and body into the spring chamber or bonnet, to assist the spring to reseat the valve. The tight clearance between these two parts assures that the bonnet cavity pressurization lags the pressure buildup under the spindle, preventing any interference with full lift.

As inlet pressure decays, the net lifting force is reduced to a point where the spindle begins to move downward. Again, the small clearance between the spindle and body guide allows F84/F85 bonnet pressure to increase the closing force on the spindle, resulting in a sharp closing action. The unique design of the F88 spindle helps assure a rapid closure with spring force and inlet pressure decay only.

Blowdown, the gap between pop pressure and reseat, in the F84 and F85 is readily controlled by adjusting the blowdown ring. Raising the ring shortens blowdown by helping increase bonnet pressure, while lowering the ring lengthens blowdown. F84's and F85's typically are set at the factory with blowdown from 7 to 10 percent, but values up to 20% can be specified. F88 blowdown is fixed at a certain percentage of set pressure, ranging from approximately 20% at pressures over 100 psig to 30-40% at lower pressures.

Superimposed backpressure in the F84 and F85 adds directly to the spring force on the spindle, and has the effect of increasing pop pressure by the value of backpressure (e.g., 5 psi of backpressure increases pop pressure by 5 psi). These valves are said to be unbalanced against backpressure. They can be set at the factory with appropriate pressure compensation (a 'cold differential test pressure', or CDTP) if superimposed backpressure is specified when ordering.

In the F88, a spindle seal of the same diameter as the seat results in the spindle being balanced against the effects of backpressure. See diagram on the next page. This valve can tolerate levels of backpressure all the way up to the pressure rating of the body, provided that system conditions will still generate flow from inlet to outlet by having a set pressure higher than backpressure.

Flow Safe is proud to offer the F80 Series safety valves to industry. We are confident that these valves present a cost-effective and reliable solution to your needs for overpressure protection.

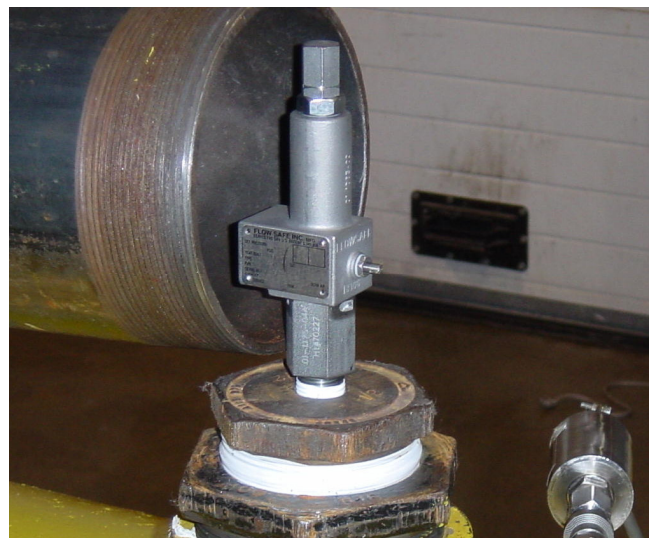
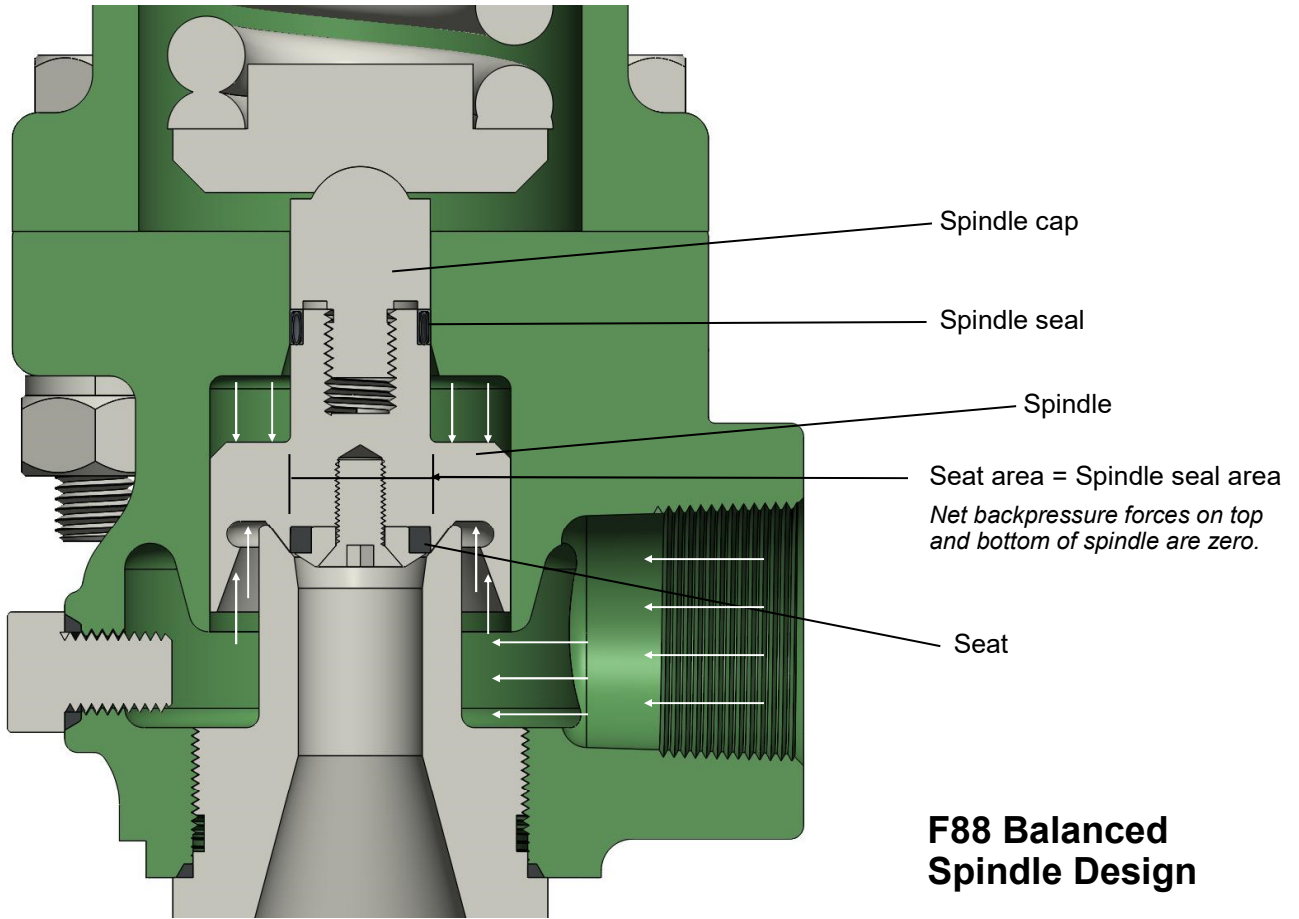

Certification flow test of F84M-1

## Model F84 / F85

Orifice Size			- 1	- 2	- 3	- 4	- 6 (D)	- 8 (E)	- F	- G	-H	- J
Orifice Dia., in (mm)			0.062 (1.57)	0.138 (3.5)	0.209 (5.3)	0.289 (7.3)	0.436 (11.1)	0.577 (14.7)	0.718 (18.2)	0.919 (23.3)	1.149 (29.2)	1.467 (37.3)
Orifice Area, in <sup>2</sup> (mm <sup>2</sup> )			0.003 (1.9)	0.015 (9.7)	0.034 (21.9)	0.065 (41.9)	0.149 (96.1)	0.261 (168)	0.405 (261)	0.664 (428)	1.036 (668)	1.689 (1089)
Min. Set Pressure, psig (barg)			15 (1.03)									
Maximum Set Pressure, psig (barg) <sup>1</sup>	M (Micro) Body - Standard	Brass	5,000 (345)	4,072 (281)	890 (61)	350 (24.1)	—	—	—	—	—	—
		CS / SS	6,600 (455)	4,072 (281)	890 (61)	350 (24.1)	—	—	—	—	—	—
	M (Micro) Body - HP block <sup>2</sup>	Brass	6,600 (455)	4,072 (281)	890 (61)	350 (24.1)	—	—	—	—	—	—
		CS / SS	10,313 (711)	4,072 (281)	890 (61)	350 (24.1)	—	—	—	—	—	—
	M (Micro) Body - 2-piece	CS / SS	10,313 (711)	9,944 (685)	—	—	—	—	—	—	—	—
		B (Medium) body	Brass	—	—	—	3,500 (241)	2,900 (200)	1,125 (77)	—	—	—
	CS / SS		—	—	—	4,921 (339)	2,900 (200)	1,125 (77)	—	—	—	—
	C, D, E body - Std. bolted bonnet	Brass	—	—	—	5,000 (344)	4,500 (310)	2,600 (179)	839 (58)	668 (46)	382 (26.3)	298 (20.5)
		CS / SS	—	—	—	9,612 (662)	5,774 <sup>3</sup> (398)	4,292 (296)	839 (58)	668 (46)	382 (26.3)	298 (20.5)
	D, E body - XL bolted bonnet	Brass	—	—	—	—	—	—	2,750 (189)	2,500 (172)	2,000 (137)	2,000 (137)
		CS / SS	—	—	—	—	—	—	5,000 (344)	3,705 (255)	2,750 (189)	2,700 (186)
	Service Temp. Range	<b>F84</b>	Brass	-325 to 406 °F (-198 to 208 °C)								
CS SS			-20 to 525 °F (-29 to 274 °C)									
Service Temp. Range	<b>F85</b>	Brass	-423 to 525 °F (-252 to 274 °C)									
		CS	-65 to 406 °F (-54 to 208 °C)									
		SS	-20 to 525 °F (-29 to 274 °C)									

<sup>1</sup> Pressure limits may vary between Models F85 and F84. See Seat Data chart on Page 7.

<sup>2</sup> The block-style body is commonly used when an MS or SAE outlet thread boss is required, regardless of pressure.

<sup>3</sup> 6100 psig (420 barg) with 1/2" or 3/4" FNPT inlet.

## Model F88

Orifice Size		- 3	- 4	- 8	- G	- J
Orifice Dia., in (mm)		0.287 (7.3) <sup>2</sup>	0.384 (9.8) <sup>2</sup>	0.577 (14.7)	0.919 (23.3)	1.467 (37.3)
Orifice Area, in <sup>2</sup> (mm <sup>2</sup> )		0.065 (41.9)	0.116 (74.8)	0.261 (168)	0.663 (428)	1.690 (1090)
Min. Set Pressure, psig (barg)		50 (3.5)				
Maximum Set Pressure, psig (barg) <sup>1</sup>	C, D, E body - Small bolted bonnet	720 (49.6)	720 (49.6)	720 (49.6)	668 (46)	298 (20.5)
	C, D, E body - XL bolted bonnet	4,292 (296)	4,292 (296)	4,292 (296)	3,705 (255)	2,700 (186)
Service Temp. Range	CS	-20 to 400 °F (-29 to 204 °C)				
	SS	-423 to 400 °F (-252 to 204 °C)				

<sup>1</sup> Pressure ratings are for standard carbon steel or stainless steel construction.

<sup>2</sup> Equivalent orifice diameter (actual orifice is annular flow area).

## SEAT DATA

F84 / F88 Seat Material	Continuous Process Temperature, °F (°C)		Pressure Range, psig (barg)					
	Min.	Max.	Orifice Size					
			-1, -2, -3	-4 <sup>2</sup>	-4 <sup>3</sup> , -6, -8	-F, -G	-H	-J
Teflon® (PTFE) <sup>1</sup>	-423 (-252)	400 (204)	15-500 (1.03-34.5)	15-500 (1.03-34.5)	15-500 (1.03-34.5)	15-500 (1.03-34.5)	15-300 (1.03-20.7)	15-145 (1.03-10)
Kel-F (PCTFE)	-423 (-252)	400 (204)	501-1000 (34.6-69)	501-2000 (34.6-138)	501-1500 (34.6-103)	501-750 (34.6-52)	301-750 (20.8-52)	146-750 (10.1-52)
Polyimide or Polyamide-imide: Vespel®, Duratron®, or equal	-423 (-252)	500 (260)	> 1000 (> 69)	> 2000 (> 138)	> 1500 (> 103)	> 750 (> 52)	> 750 (> 52)	> 750 (> 52)
Polyetheretherketone (PEEK)	0 (-18)	525 (274)	> 1000 (> 69)	> 2000 (> 138)	> 1500 (> 103)	> 750 (> 52)	> 750 (> 52)	> 750 (> 52)
<b>F85 Seat Material</b>								
Buna-N	-30 (-34)	275 (135)	15 - 1480 (1.03 - 102)					
Fluorocarbon: Viton® or equal	-30 (-34)	400 (204)						
Ethylene propylene (EPR / EPDM)	-65 (-54)	325 (163)						
Perfluoroelastomer: Kalrez®, Chemraz®, or equal	0 (-18)	525 (274)						
Polyurethane	-65 (-54)	225 (107)	15-10,313 (1.03-711)	(Contact factory)				

<sup>1</sup> Ekonol-filled PTFE may be substituted.

<sup>2</sup> Applies to F84-4

<sup>3</sup> Applies to F88-4

Teflon, Vespel, Viton, and Kalrez are registered trademarks of E.I. Du Pont de Nemours and Co. or affiliates. Chemraz is a registered trademark of Greene, Tweed. Duratron is a registered trademark of Quadrant Engineering Plastic Products.

## THREADED CONNECTIONS

Model	Orifice Size	Body Size	Weight <sup>1</sup> , lb (kg)	Standard Connections <sup>2</sup>		Dimensions, in (mm) <sup>1</sup>		
				Inlet	Outlet	A	B	C <sup>3</sup>
F84M / F85M	- 1, - 2, - 3, - 4	M - Standard	1.7 (0.8)	1/2", 3/4" MNPT <sup>4</sup>	1/2", 3/4" FNPT	2.93 (74)	1.30 (33)	6.7 (170)
F84M / F85M	- 1, - 2, - 3, - 4	M - HP block	3.2 (1.5)	3/4" M/P coned & threaded	1/2", 3/4" FNPT	2.00 (51)	1.50 (38)	6.0 (152)
F84M / F85M	- 1, - 2	M - 2-piece	2.9 (1.3)	1/2", 3/4" MNPT	1/2", 3/4" FNPT	2.93 (74)	1.50 (38)	8.4 (213)
F84 / F85	- 4, - 6, - 8	B	5.3 (2.4)	3/4", 1" FNPT <sup>4</sup>	1" FNPT	2.65 (67)	2.07 (53)	9.9 (251) LL - 11.3 (287)
				3/4", 1" MNPT	1" FNPT	3.20 (81)	2.07 (53)	10.4 (264) LL - 11.8 (300)
F84 / F85	- 4, - 6, - 8	C	12.9 (5.9)	3/4", 1" FNPT <sup>4</sup>	1" FNPT	2.65 (67)	2.07 (53)	13.1 (333) LL - 14.5 (368)
F88	- 3, - 4, - 8	C - Small	9.8 (4.4)	3/4", 1" FNPT <sup>4</sup>	1" FNPT	2.65 (67)	2.07 (53)	10.8 (274) LL - 12.2 (310)
F88	- 3, - 4, - 8	C - XL	12.9 (5.9)	3/4", 1" FNPT <sup>4</sup>	1" FNPT	2.65 (67)	2.07 (53)	13.1 (333) LL - 14.5 (368)
F84 / F85 / F88	- F, - G	D - Standard	32 (15)	1-1/2" FNPT	2" FNPT	2.60 (66)	3.15 (80)	14.4 (366) LL - 17.0 (432)
F84 / F85 / F88	- F, - G	D - XL	41 (19)	1-1/2" FNPT	2" FNPT	2.60 (66)	3.15 (80)	17.8 (452) LL - 20.4 (518)
F84 / F85 / F88	- H, - J	E - Standard	46 (21)	2" FNPT <sup>4</sup>	3" FNPT	2.72 (69)	4.25 (108)	14.8 (376) LL - 17.4 (442)
F84 / F85 / F88	- H, - J	E - XL	70 (32)	2" FNPT <sup>4</sup>	3" FNPT	2.72 (69)	4.25 (108)	22.0 (559) LL - 24.6 (625)

<sup>1</sup> Dimensions are typical and subject to change without notice. Contact Flow Safe for submittal drawing whenever specific dimensions are needed for construction.

<sup>2</sup> Other connection sizes and types are available, including SAE or MS / AS5202 thread bosses. "Coned & threaded" connection accepts Butech, Autoclave, or equivalent male tubing, collar, and gland.

<sup>3</sup> LL = Dimension with lift lever

<sup>4</sup> F84M/F85M-1 and -2 are available with 1/4" inlet; F88-3, F84/F85/F88-4, and F84/F85-6 are available with 1/2" female inlet; F84/F85-H is available with 1-1/2" inlet.

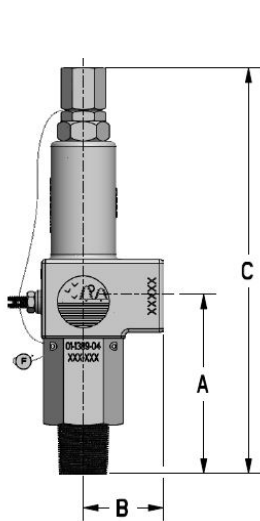

**M (Micro) Body**

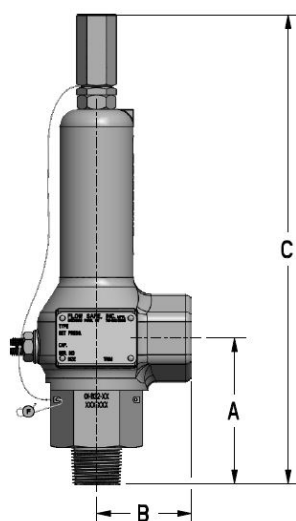

**B (Medium) Body**

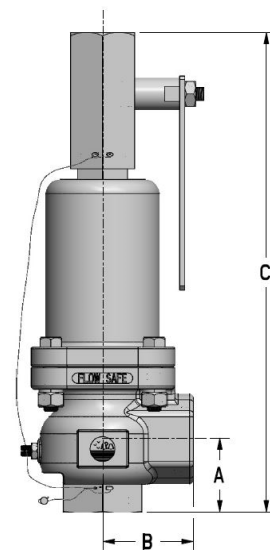

**C, D, E Body - Bolted Bonnet**  
(Lift lever shown)

## FLANGED CONNECTIONS

Model	Orifice Size	Body Size	Weight <sup>1</sup> , lb (kg)	Standard Connections <sup>2</sup>		Dimensions, in (mm) <sup>1</sup>		
				Inlet	Outlet	A	B	C <sup>3</sup>
F84M / F85M	- 1, - 2, - 3, - 4	M - Standard		(Contact factory)				
F84M / F85M	- 1, - 2, - 3, - 4	M - HP block						
F84M / F85M	- 1, - 2	M - 2-piece						
F84 / F85	- 4, - 6, - 8	B	22 (10)	1" 150-600#	1" 150#	4.72 (120)	4.75 (121)	11.9 (302)
				1" 900-2500#	1" 300#	5.72 (145)	6.75 (171)	LL - 13.3 (338) 12.9 (328) LL - 14.3 (363)
F84 / F85	- 4, - 6, - 8	C	29 (13)	1" 900-2500#	1" 300#	5.72 (145)	6.75 (171)	16.2 (411) LL - 17.6 (447)
F88	- 3, - 4, - 8	C - Small	13 (6)	1" 150-600#	1" 150#	4.72 (120)	4.75 (121)	12.9 (328) LL - 14.3 (363)
F88	- 3, - 4, - 8	C - XL	29 (13)	1" 900-2500#	1" 300#	5.72 (145)	6.75 (171)	16.2 (411) LL - 17.6 (447)
F84 / F85 / F88	- F, - G	D - Standard	54 (24)	1-1/2" 150-600#	2" 150#	4.87 (124)	4.75 (121)	16.6 (422) LL - 19.2 (488)
F84 / F85 / F88	- F, - G	D - XL	62 (28)	1-1/2" 900/1500#	2" 300#	5.25 (133)	5.06 (129)	20.4 (518) LL - 23.0 (584)
F84 / F85 / F88	- H, - J	E - Standard	87 (39)	2" 150-600#	3" 150#	5.37 (136)	6.50 (165)	17.5 (445) LL - 20.1 (511)
F84 / F85 / F88	- H, - J	E - XL	105 (48)	2" 900/1500#	3" 300#	6.56 (167)	7.00 (178)	25.9 (658) LL - 28.5 (724)

<sup>1</sup> Dimensions are typical and subject to change without notice. Weights are approximate and include maximum flange ratings. Flange facing must be specified (RF, RTJ, or other). Contact Flow Safe for submittal drawing whenever specific dimensions are needed for construction. API 526 dimensions available on request for applicable orifice and connection sizes.

<sup>2</sup> Other sizes and welded connection types are available, including Grayloc hubs and Swagelok VCR. Contact factory for details.

<sup>3</sup> LL = Dimension with lift lever

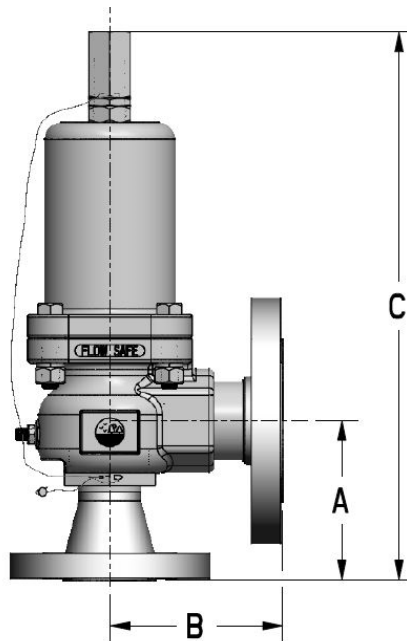

# F84 CONSTRUCTION

F80 Series

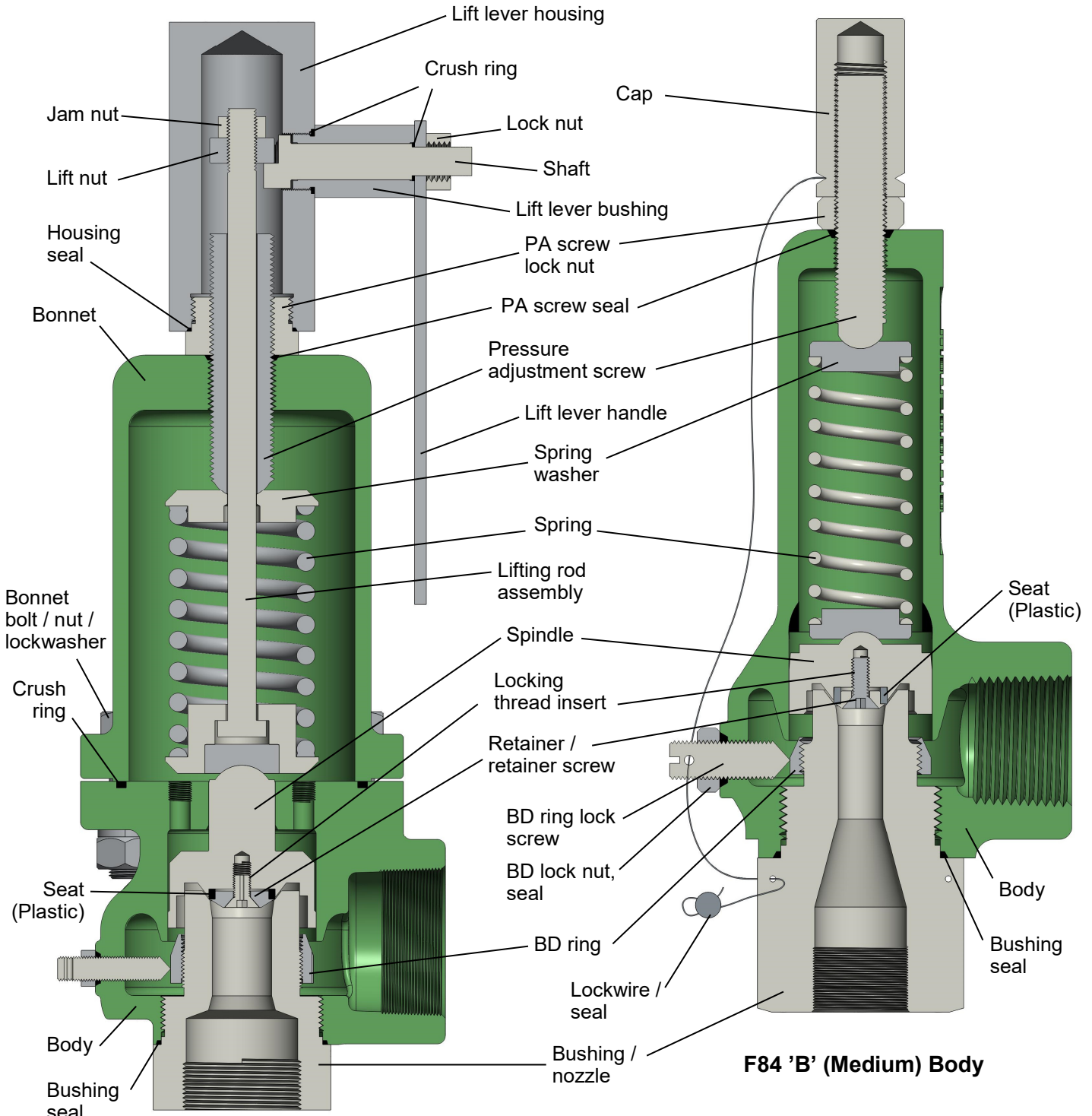

**F84 'C' / 'D' / 'E' Body with Lift Lever**

**F84 'B' (Medium) Body**

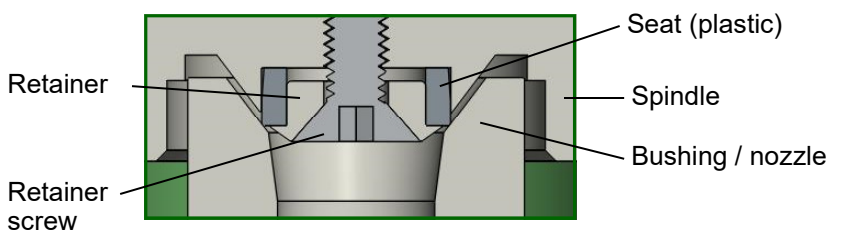

**F84 Seat Detail**

F84 Part Name	Standard Materials of Construction <sup>1</sup>		
	Brass	Carbon Steel (NACE)	Stainless Steel (NACE)
Body - standard / Micro block	SB-61 C92200 / B16	SA-351 CF8M	SA-351 CF8M
Body - Micro 2-piece	—	SA-479 316/316L	SA-479 316/316L
Bonnet	SA-351 CF8M	SA-216 WCB	SA-351 CF8M
Spring	A313 302/304 or 17-7	A401 chromium-silicon (Inconel X750 or Elgiloy)	A313 302/304 or 17-7 (Inconel X750 or Elgiloy)
Spring washer	B16 C36000	CS / plated (316 SS)	A479 316/316L
Cap	6061 Aluminum	6061 Aluminum	6061 Aluminum
Pressure adjustment screw	B16 C36000	Carbon steel / plated	A479 316/316L
Blowdown (BD) ring	B16 C36000	A479 316/316L	A479 316/316L
BD ring lock screw	Monel	316 SS	316 SS
Lock nuts, jam nuts, lift nut	316 SS	316 SS	316 SS
Bonnet bolt	SA-193 Gr. B8 Cl. 1 or 2	SA-193 Gr. B8 Cl. 1 or 2	SA-193 Gr. B8 Cl. 1 or 2
Nut	SA-194 Gr. 8	SA-194 Gr. 8	SA-194 Gr. 8
Lockwasher	316 SS	316 SS	316 SS
Bushing / nozzle	B16 C36000 H02	SA-479 316/316L	SA-479 316/316L
Spindle	B16 C36000	A479 316/316L	A479 316/316L
Seat	Plastic <sup>2</sup>	Plastic <sup>2</sup>	Plastic <sup>2</sup>
Retainer	B16 C36000	A479 316/316L	A479 316/316L
Retainer screw	Monel or brass	316 SS	316 SS
Locking thread insert	304 SS	304 SS (Inconel X750)	304 SS (Inconel X750)
Crush rings, seals	Teflon / PTFE	Teflon / PTFE	Teflon / PTFE
Lockwire	18-8 SS	18-8 SS	18-8 SS
Seal	Lead	Lead	Lead
Lifting rod assembly <sup>3</sup>	316 SS	316 SS	316 SS
Lift lever housing, bushing <sup>3</sup>	SA-479 316/316L	SA-479 316/316L	SA-479 316/316L
Shaft <sup>3</sup>	17-4 SS	17-4 SS	17-4 SS
Lift lever handle <sup>3</sup>	316 SS	316 SS	316 SS

<sup>1</sup> Materials are subject to change without notice. Contact Flow Safe for availability of materials not shown. See p. 15 for available flange materials not shown here. NACE trim is in accordance with NACE MR0175 / ISO 15156.

<sup>2</sup> See "Seat Data" on p. 7 for selections.

<sup>3</sup> Lift levers are available on all valve body sizes except 'Micro'.

**F84M 'M' (Micro)  
Body - 2-Piece**

*F84M-1 w/ coned & threaded inlet shown*

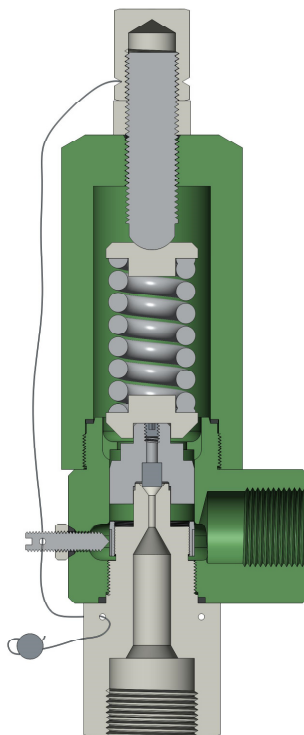

**F84M 'M' (Micro)  
Body - Standard**

*F84M-4 w/ NPT connections shown*

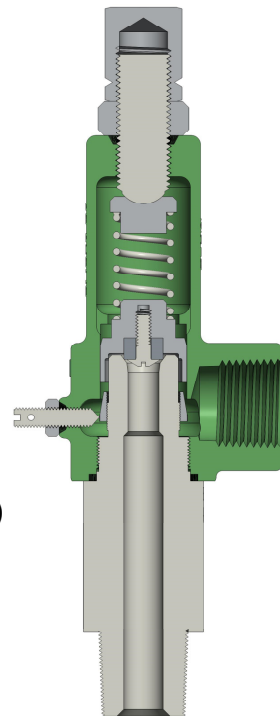

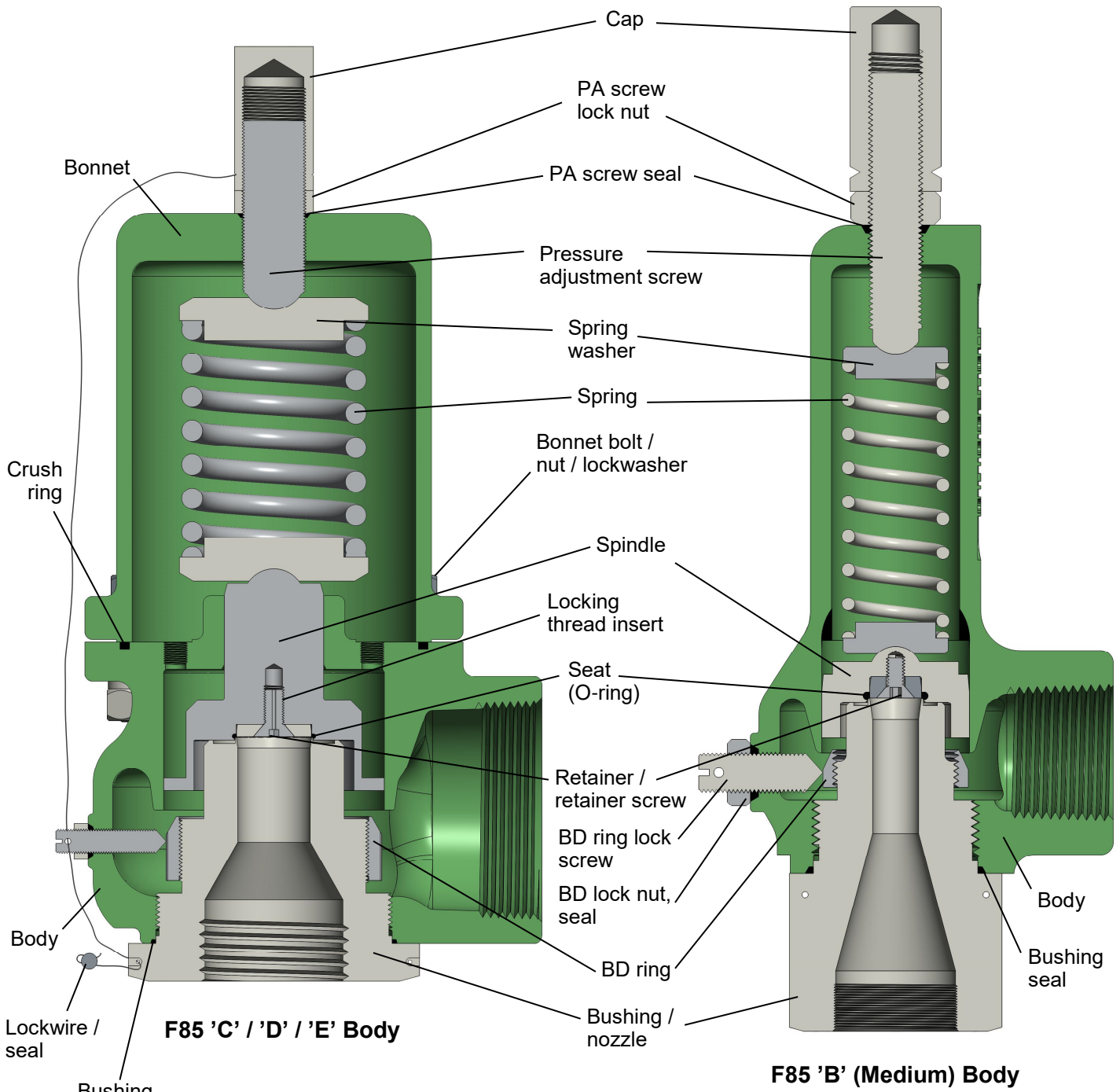

**F85 'C' / 'D' / 'E' Body**

**F85 'B' (Medium) Body**

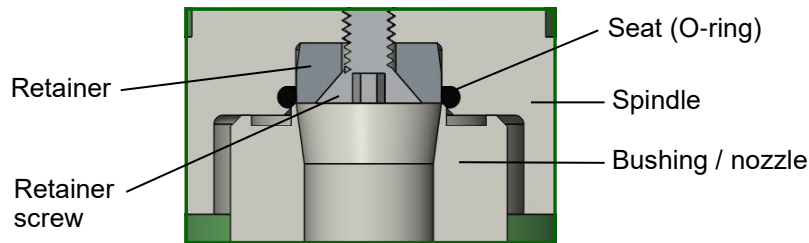

**F85 Seat Detail**

See pp. 8-9 for dimensions and weights.

F85 Part Name	Standard Materials of Construction <sup>1,3</sup>		
	Brass	Carbon Steel (NACE)	Stainless Steel (NACE)
Body - standard / Micro block	SB-61 C92200 / B16	SA-351 CF8M	SA-351 CF8M
Body - Micro 2-piece	—	SA-479 316/316L	SA-479 316/316L
Bonnet	SA-351 CF8M	SA-216 WCB	SA-351 CF8M
Spring	A313 302/304 or 17-7	A401 chromium-silicon (Inconel X750 or Elgiloy)	A313 302/304 or 17-7 (Inconel X750 or Elgiloy)
Spring washer	B16 C36000	CS / plated (316 SS)	A479 316/316L
Cap	6061 Aluminum	6061 Aluminum	6061 Aluminum
Pressure adjustment screw	B16 C36000	Carbon steel / plated	A479 316/316L
Blowdown (BD) ring	B16 C36000	A479 316/316L	A479 316/316L
BD ring lock screw	Monel	316 SS	316 SS
Lock nuts, jam nuts, lift nut	316 SS	316 SS	316 SS
Bonnet bolt	SA-193 Gr. B8 Cl. 1 or 2	SA-193 Gr. B8 Cl. 1 or 2	SA-193 Gr. B8 Cl. 1 or 2
Nut	SA-194 Gr. 8	SA-194 Gr. 8	SA-194 Gr. 8
Lockwasher	316 SS	316 SS	316 SS
Bushing / nozzle	B16 C36000 H02	SA-479 316/316L	SA-479 316/316L
Spindle	B16 C36000	A479 316/316L	A479 316/316L
Seat	Elastomer <sup>2</sup>	Elastomer <sup>2</sup>	Elastomer <sup>2</sup>
Retainer	B16 C36000	A479 316/316L	A479 316/316L
Retainer screw	Monel or brass	316 SS	316 SS
Locking thread insert	304 SS	304 SS (Inconel X750)	304 SS (Inconel X750)
Crush rings, seals	Teflon / PTFE	Teflon / PTFE	Teflon / PTFE
Lockwire	18-8 SS	18-8 SS	18-8 SS
Seal	Lead	Lead	Lead

<sup>1</sup> Materials are subject to change without notice. Contact Flow Safe for availability of materials not shown. See p. 15 for available flange materials not shown here. NACE trim is in accordance with NACE MR0175 / ISO 15156.

<sup>2</sup> See "Seat Data" on p. 7 for selections.

<sup>3</sup> Lift levers are available on all valve body sizes except 'Micro'. Lift lever construction is as shown on pp. 10 - 11.

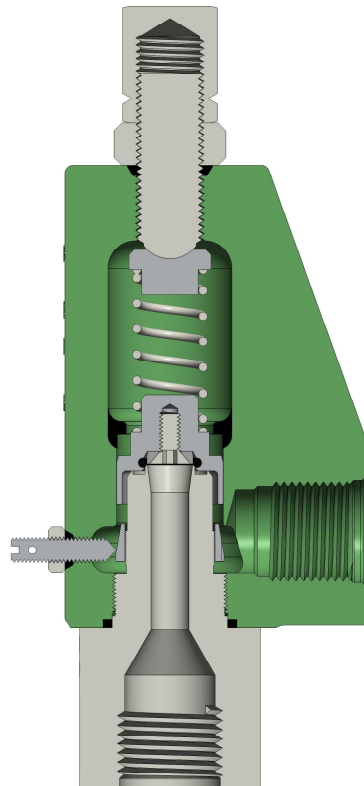

**F85M 'M' (Micro)  
Body - HP Block**

*F85M-4 w/ SAE AS5202  
connections shown*

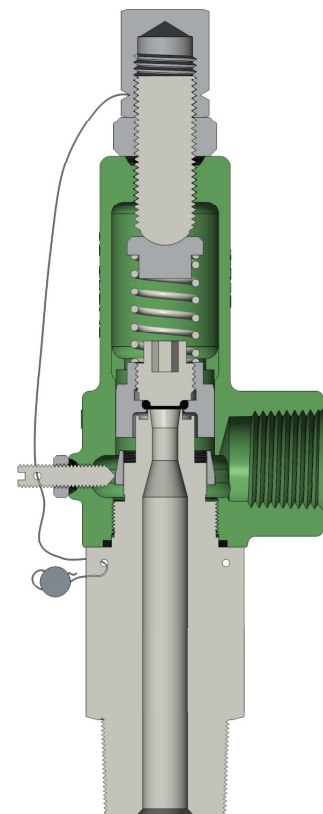

**F85M 'M' (Micro)  
Body - Standard**

*F85M-3 w/ NPT  
connections shown*

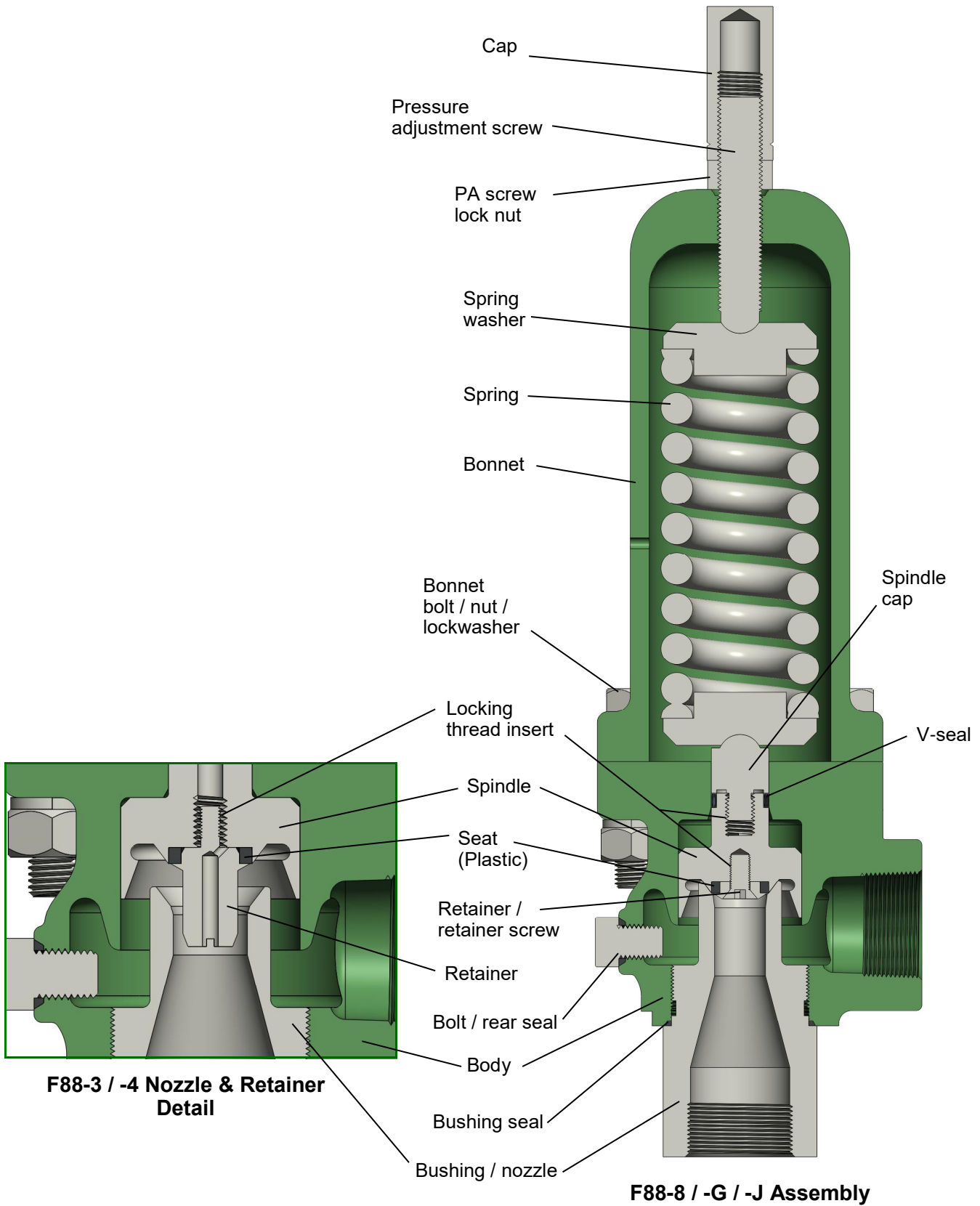

F88 Part Name	Standard Materials of Construction <sup>1, 3</sup>	
	Carbon Steel (NACE)	Stainless Steel (NACE)
Body	SA-351 CF8M	SA-351 CF8M
Bonnet	SB-221 6061 or SA-216 WCB	SA-479 316/316L or SA-351 CF8M
Spring	A401 chromium-silicon	A313 302/304 or 17-7
Spring washer	Carbon steel / plated	A479 316/316L
Cap	6061 Aluminum	6061 Aluminum
Pressure adjustment screw	Carbon steel / plated	A479 316/316L
PA screw lock nut	316 SS	316 SS
Bonnet bolt	SA-193 Gr. B8	SA-193 Gr. B8
Nut	SA-194 Gr. 8	SA-194 Gr. 8
Lockwasher	316 SS	316 SS
Bushing / nozzle	SA-479 316/316L	SA-479 316/316L
Spindle	A479 316/316L	A479 316/316L
Spindle cap	A479 316/316L	A479 316/316L
Seat	Plastic <sup>2</sup>	Plastic <sup>2</sup>
Retainer	A479 316/316L	A479 316/316L
Retainer screw (-8, -G, -J)	316 SS	316 SS
Locking thread insert	304 SS (Inconel X750)	304 SS (Inconel X750)
V-seal	Teflon w/316 SS (Elgiloy) spring	Teflon w/316 SS (Elgiloy) spring
Bolt	316 SS	316 SS
Bushing & rear seals	Teflon / PTFE	Teflon / PTFE
Flange or Grayloc hub (optional)	SA-105	SA-182 F316/316L
Pipe (optional)	SA-106 B or SA-53 E/B	SA-312 316/316L

<sup>1</sup> Materials are subject to change without notice. Contact Flow Safe for availability of materials not shown. NACE trim is in accordance with NACE MR0175 / ISO 15156.

<sup>2</sup> See "Seat Data" on p. 7 for selections.

<sup>3</sup> Lift levers are available on all F88 valve body sizes.

**F88-8 / -G / -J  
Flanged Assembly**

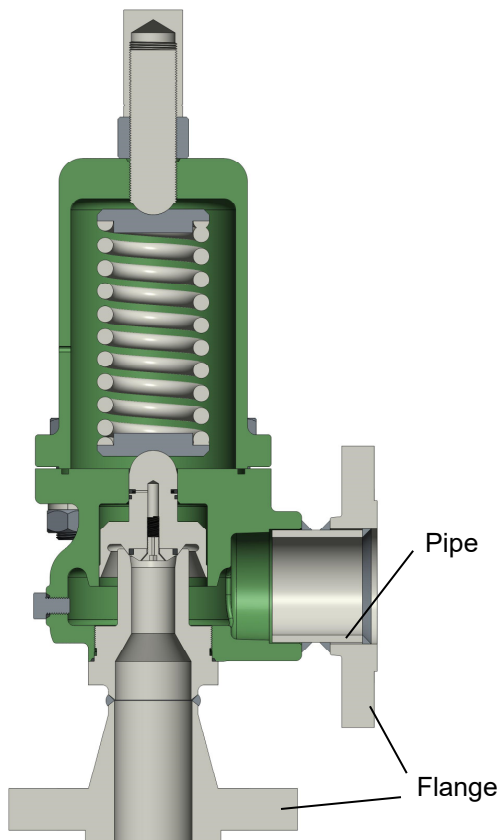

## SIZING FOR GAS & VAPOR SERVICE

The ASME Boiler & Pressure Vessel Code, Section VIII, requires that capacity certification be obtained for pressure relief valves designed for gas or vapor service. Certification tests include determination of the rated coefficient of discharge for the PRVs at an overpressure of 10% or 3 psi, whichever is greater.

To size the F80 series relief valve for gas or vapor service, the following information is required:

- Required flow capacity
- Required set pressure
- Backpressure (pressure at valve outlet)
- Acceptable overpressure [10% or 3 psi max.; 21% for fire case per ASME VIII, UG-125(c)(2)]
- Operating pressure, to assure that it is below valve reseal pressure
- Gas properties, including molecular weight, specific heat ratio or gas constant, and compressibility factor

To select the required orifice size for a gas or vapor application, the below equations should be used. Depending on the gas, critical flow generally exists at pressures above 11 to 12 psig with zero backpressure, or at higher pressures where backpressure is less than approximately 50% of inlet pressure. If backpressure is less than or equal to  $P_{cf}$  in the following equation, critical flow will occur:

$$P_{cf} = P_1 \left[ \frac{2}{k+1} \right]^{\frac{k}{k-1}}$$

### Critical Flow

In US customary units:

$$A = \frac{V \sqrt{MTZ}}{6.320 K_d P_1 K_b K_c}$$

- OR -

$$A = \frac{W}{CK_d P_1 K_b K_c} \sqrt{\frac{TZ}{M}}$$

In SI units:

$$A = \frac{2.676V \sqrt{MTZ}}{CK_d P_1 K_b K_c}$$

- OR -

$$A = \frac{W}{CK_d P_1 K_b K_c} \sqrt{\frac{TZ}{M}}$$

### Subcritical Flow

In US customary units:

$$A = \frac{V}{4645 F_2 K_d K_c} \sqrt{\frac{MTZ}{P_1(P_1 - P_2)}}$$

- OR -

$$A = \frac{W}{735 F_2 K_d K_c} \sqrt{\frac{TZ}{MP_1(P_1 - P_2)}}$$

In SI units:

$$A = \frac{47.95V}{F_2 K_d K_c} \sqrt{\frac{MTZ}{P_1(P_1 - P_2)}}$$

- OR -

$$A = \frac{17.9W}{F_2 K_d K_c} \sqrt{\frac{TZ}{MP_1(P_1 - P_2)}}$$

- A = Required discharge orifice area, in<sup>2</sup> or mm<sup>2</sup>
- V = Required flow rate, scfm or Nm<sup>3</sup>/min
- W = Required flow rate, lb/hr or kg/hr
- K<sub>d</sub> = Rated ASME discharge coefficient (See table headings, pp. 20 - 25)
- C = Gas constant, dependent on specific heat ratio  $k = C_p/C_v$  (See table on p. 17)
- P<sub>1</sub> = Relieving pressure (set pressure plus overpressure plus atmospheric pressure), psia or kPaa
- P<sub>2</sub> = Backpressure, psia or kPaa
- K<sub>b</sub> = Backpressure correction factor, for balanced bellows valves only (otherwise, use 1.0)
- K<sub>c</sub> = Rupture disk correction factor: 1.0 with no disk  
0.9 with disk in combination
- M = Molecular weight at inlet relieving conditions (See table on p. 18)
- T = Relieving temperature, °R (°F + 460) or °K (°C + 273)
- Z = Compressibility factor at inlet relieving conditions, 1.0 if unknown
- F<sub>2</sub> = Coefficient of subcritical flow; See figure on p. 18
- k = Specific heat ratio, C<sub>p</sub>/C<sub>v</sub> (See table on p. 18)
- P<sub>cf</sub> = Critical flow nozzle pressure, psia or kPaa

See p. 19 for sizing example.

## SIZING FOR GAS & VAPOR SERVICE (cont'd)

### Values of Coefficient C (For equations on p. 16)

k	C		k	C		k	C		k	C	
	USC	SI		USC	SI		USC	SI		USC	SI
1.00	315	0.0239	1.26	343	0.0261	1.51	365	0.0277	1.76	384	0.0292
1.01	317	0.0240	1.27	344	0.0261	1.52	366	0.0278	1.77	385	0.0292
1.02	318	0.0241	1.28	345	0.0262	1.53	367	0.0279	1.78	386	0.0293
1.03	319	0.0242	1.29	346	0.0263	1.54	368	0.0279	1.79	386	0.0293
1.04	320	0.0243	1.30	347	0.0263	1.55	369	0.0280	1.80	387	0.0294
1.05	321	0.0244	1.31	348	0.0264	1.56	369	0.0280	1.81	388	0.0294
1.06	322	0.0245	1.32	349	0.0265	1.57	370	0.0281	1.82	389	0.0295
1.07	323	0.0246	1.33	350	0.0266	1.58	371	0.0282	1.83	389	0.0296
1.08	325	0.0246	1.34	351	0.0266	1.59	372	0.0282	1.84	390	0.0296
1.09	326	0.0247	1.35	352	0.0267	1.60	373	0.0283	1.85	391	0.0297
1.10	327	0.0248	1.36	353	0.0268	1.61	373	0.0283	1.86	391	0.0297
1.11	328	0.0249	1.37	353	0.0268	1.62	374	0.0284	1.87	392	0.0298
1.12	329	0.0250	1.38	354	0.0269	1.63	375	0.0285	1.88	393	0.0298
1.13	330	0.0251	1.39	355	0.0270	1.64	376	0.0285	1.89	393	0.0299
1.14	331	0.0251	1.40	356	0.0270	1.65	376	0.0286	1.90	394	0.0299
1.15	332	0.0252	1.41	357	0.0271	1.66	377	0.0286	1.91	395	0.0300
1.16	333	0.0253	1.42	358	0.0272	1.67	378	0.0287	1.92	395	0.0300
1.17	334	0.0254	1.43	359	0.0272	1.68	379	0.0287	1.93	396	0.0301
1.18	335	0.0254	1.44	360	0.0273	1.69	379	0.0288	1.94	397	0.0301
1.19	336	0.0255	1.45	360	0.0274	1.70	380	0.0289	1.95	397	0.0302
1.20	337	0.0256	1.46	361	0.0274	1.71	381	0.0289	1.96	398	0.0302
1.21	338	0.0257	1.47	362	0.0275	1.72	382	0.0290	1.97	398	0.0302
1.22	339	0.0258	1.48	363	0.0276	1.73	382	0.0290	1.98	399	0.0303
1.23	340	0.0258	1.49	364	0.0276	1.74	383	0.0291	1.99	400	0.0303
1.24	341	0.0259	1.50	365	0.0277	1.75	384	0.0291	2.00	400	0.0304
1.25	342	0.0260	—	—	—	—	—	—	—	—	—

## SIZING FOR GAS & VAPOR SERVICE (cont'd)

### Common Gas Properties

Gas	Molecular Weight	Specific Heat Ratio, $k$ ( $C_p/C_v$ )	Gas	Molecular Weight	Specific Heat Ratio, $k$ ( $C_p/C_v$ )
Acetylene	26	1.28	Hydrogen Sulfide	34	1.32
Air	29	1.40	Isobutane	58	1.10
Ammonia	17	1.30	Isopentane	72	1.08
Argon	40	1.66	Methane	16	1.31
Benzene	78	1.12	Methyl Chloride	50	1.20
n-Butane	58	1.09	Natural Gas	19	1.27
Carbon Dioxide	44	1.29	Nitrogen	28	1.40
Chlorine	71	1.36	Oxygen	32	1.40
Ethane	30	1.19	n-Pentane	72	1.08
Ethylene	28	1.24	Propane	44	1.13
Helium	4	1.66	Propylene	42	1.15
n-Hexane	86	1.06	Sulfur Dioxide	64	1.27
Hydrogen	2	1.41	Water vapor / steam	18	1.33

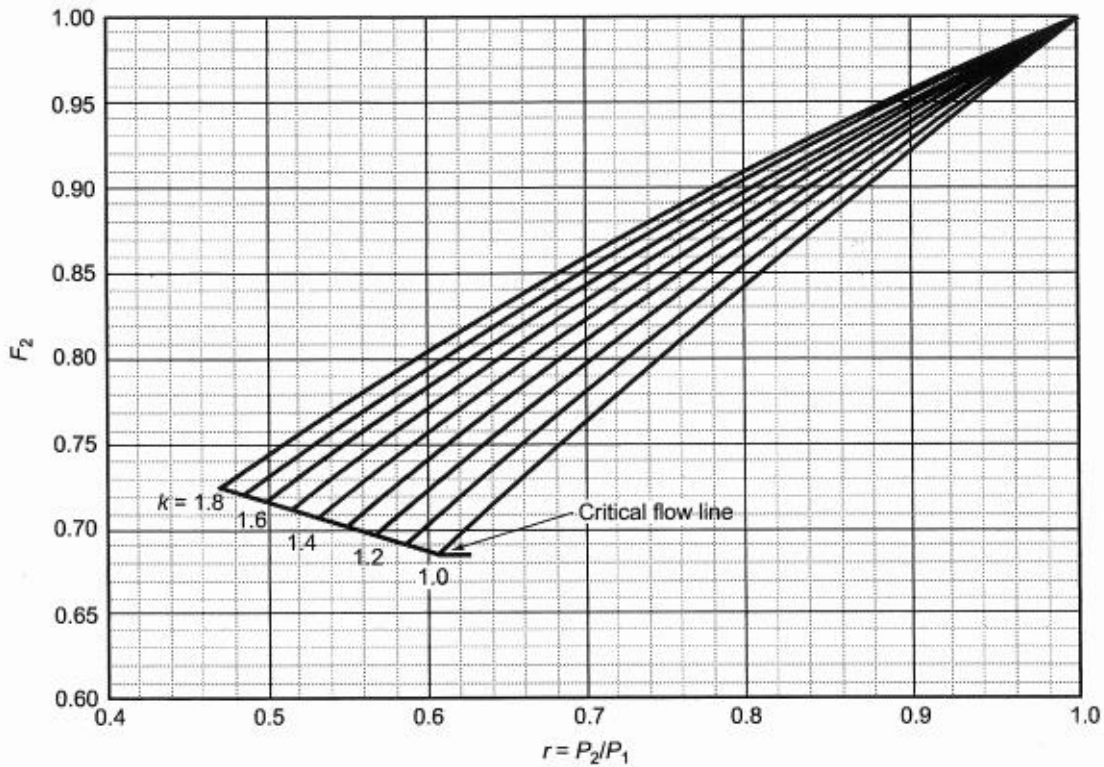

### Values of $F_2$ for Subcritical Flow

(For equations on p. 16)

## SIZING FOR GAS & VAPOR SERVICE (cont'd)

### GAS SIZING EXAMPLE

Service conditions: Set pressure = 1200 psig; 10% overpressure; 60 psig backpressure  
 Natural gas at 120 °F; Compressibility factor = 0.95  
 Capacity required = 22,000 scfm  
 Assume Model F84/F85 and associated discharge coefficient (see top of pp. 20 - 22)

Check critical flow pressure:

$$P_{cf} = P_1 \left[ \frac{2}{k+1} \right]^{\frac{k}{k-1}}$$

$$= [(1200)(1.10) + 14.7] \cdot [2 / (1.27 + 1)]^{1.27 / (1.27 - 1)}$$

$$= 736 \text{ psia}$$

Backpressure is less than  $P_{cf}$ , so critical flow will occur.

Choose critical flow equation from p. 16 that uses "scfm" for flow units:

$$A = \frac{V \text{ MTZ}}{6.32 C_d K_b K_c P_1 \sqrt{Z}}$$

$$= \frac{22,000 (19)(460 + 120)(0.95)}{6.32(344)(0.878)(1334.7)(1)(1)} = 0.884 \text{ in}^2$$

Select F84/F85 with "H" orifice (1.036 in<sup>2</sup>) from orifice size listing in table on p. 6.

Based on inlet pressure and temperature, the XL bolted bonnet will be required in carbon or stainless steel.

## SIZING FOR TWO-PHASE FLOW

To size the F80 relief valves for mixed gas and liquid service, with flashing or non-flashing flow, the Omega Method from API 520 Part I may be used. The following information is required, in addition to required flow capacity, set pressure, etc.:

- Specific volume of the 2-phase fluid system at the relief valve inlet (ft<sup>3</sup>/lb or m<sup>3</sup>/kg)
- Specific volume evaluated at 90% of the relief valve inlet pressure (ft<sup>3</sup>/lb or m<sup>3</sup>/kg)

The ASME Code and National Board of Boiler & Pressure Vessel Inspectors rules do not give specific guidance on nameplate stamping (i.e., capacity) in mixed-phase applications. However, good engineering judgment would dictate that the valve be marked for gas or liquid based on the fluid that makes up the greater percentage of the flow stream. As the F88 is certified on both gas and liquid, this would normally be the best choice for two-phase flow. The F84 and F85 should be limited to small traces of liquid in a substantially gas fluid stream.

# SIZING / CAPACITIES

**F80 Series**

**F84 / F85 FLOW CAPACITIES:  $K_d = 0.878$   
10% / 3 psig Overpressure, 0 BP, 60 °F, Z=1.0, MW=29**

**AIR**

Orifice Size:	- 1	- 2	- 3	- 4	- 6	- 8	- F	- G	- H	- J
Orifice Area, in <sup>2</sup> (mm <sup>2</sup> ):	0.003 (1.9)	0.015 (9.7)	0.034 (21.9)	0.065 (41.9)	0.149 (96.1)	0.261 (168)	0.405 (261)	0.664 (428)	1.036 (668)	1.689 (1089)
Set Pressure, psig	SCFM	SCFM	SCFM	SCFM	SCFM	SCFM	SCFM	SCFM	SCFM	SCFM
15	1.6	7.9	17	34	78	137	213	349	545	888
25	2.1	10	23	44	102	179	278	456	711	1160
50	3.4	16	38	72	167	292	454	744	1161	1893
75	4.7	23	53	101	233	408	633	1038	1619	2640
100	6.0	30	68	130	298	523	812	1332	2078	3388
150	8.7	43	98	187	430	754	1170	1919	2994	4882
200	11	56	128	245	562	985	1529	2506	3911	6376
250	14	69	158	302	694	1216	1887	3094	4828	7871
300	16	83	188	360	826	1447	2245	3681	5744	9365
400	21	109	248	475	1089	1909	2962	4856	7577	12354
500	27	136	308	590	1353	2370	3679	6031	9411	15342
750	40	202	459	878	2012	3525	5470	8969	13994	22814
890	48	239	543	1039	2381	4172	6474	10614	16560	26998
1000	53	269		1165	2671	4680	7262	11906	18577	30286
1500	80	401		1740	3990	6989	10845	17781	27743	45230
2000	106	534		2315	5308	9298	14428	23656	36909	60173
2500	133	667		2890	6626	11607	18012	29530	46075	75117
2700	144	720		3120	7154	12531	19445	31880	49741	81094
2750	146	733		3178	7285	12762	19803	32468	50658	
3000	160	799		3465	7945	13917	21595	35405		
3500	186	932		4041	9263	16226	25178	41280		
3705	197	987		4276	9803	17173	26647	43689		
4000	213	1065		4616	10581	18535	28761			
4072	216	1084		4698	10771	18868	29277			
4292	228	1142		4952	11351	19884	30854			
5000	266	1330		5766	13218		35928			
5774	307	1536		6656	15258					
6000	319	1596		6916						
7000	372	1861		8066						
8000	425	2127		9216						
9000	478	2392		10367						
9612	511	2554		11070						
9944	528	2643								
10313	548									

# SIZING / CAPACITIES

**F80 Series**

**F84 / F85 FLOW CAPACITIES:  $K_d = 0.878$**   
**10% / 3 psi Overpressure, 0 BP, 60 °F, Z=1.0, MW=19**

**NAT. GAS**

Orifice Size:	- 1	- 2	- 3	- 4	- 6	- 8	- F	- G	- H	- J
Orifice Area, in <sup>2</sup> (mm <sup>2</sup> ):	0.003 (1.9)	0.015 (9.7)	0.034 (21.9)	0.065 (41.9)	0.149 (96.1)	0.261 (168)	0.405 (261)	0.664 (428)	1.036 (668)	1.689 (1089)
Set Pressure, psig	SCFM	SCFM	SCFM	SCFM	SCFM	SCFM	SCFM	SCFM	SCFM	SCFM
15	1.9	9.4	21	40	93	163	254	417	650	1060
25	2.5	12	27	53	122	214	332	544	849	1385
50	4.0	20	45	87	199	349	542	888	1386	2260
75	5.6	28	63	121	278	487	756	1239	1933	3152
100	7.2	35	81	155	356	625	969	1590	2480	4044
150	10	51	117	224	514	900	1397	2291	3575	5828
200	13	67	153	293	671	1176	1825	2992	4669	7612
250	16	83	189	361	828	1452	2253	3694	5763	9396
300	19	99	225	430	986	1727	2680	4395	6857	11180
400	26	131	296	567	1301	2279	3536	5798	9046	14748
500	32	162	368	704	1615	2830	4392	7200	11234	18316
750	48	241	548	1048	2402	4208	6530	10707	16706	27236
890	57	286	648	1240	2843	4980	7728	12671	19770	32231
1000	64	321		1391	3189	5587	8669	14214	22177	36155
1500	95	479		2078	4763	8343	12947	21227	33119	53995
2000	127	638		2764	6337	11100	17225	28240	44062	71835
2500	159	796		3451	7910	13857	21502	35253	55004	89674
2700	172	859		3725	8540	14960	23213	38059	59381	96810
2750	175	875		3794	8697	15235	23641	38760	60475	
3000	191	954		4137	9484	16614	25780	42267		
3500	222	1113		4824	11058	19370	30058	49280		
3705	235	1178		5105	11703	20501	31812	52156		
4000	254	1271		5510	12632	22127	34335			
4072	258	1294		5609	12858	22524	34951			
4292	272	1364		5911	13551	23737	36834			
5000	317	1588		6883	15779		42891			
5774	366	1833		7946	18215					
6000	381	1905		8256						
7000	444	2222		9629						
8000	507	2539		11003						
9000	571	2856		12376						
9612	610	3049		13216						
9944	631	3155								
10313	654									

**F84 / F85 FLOW CAPACITIES:  $K_d = 0.878$**   
**10% / 3 psi Overpressure, 0 BP, 60 °F, Z=1.0, MW=2**

## HYDROGEN

Orifice Size:	- 1	- 2	- 3	- 4	- 6	- 8	- F	- G	- H	- J
Orifice Area, in <sup>2</sup> (mm <sup>2</sup> ):	0.003 (1.9)	0.015 (9.7)	0.034 (21.9)	0.065 (41.9)	0.149 (96.1)	0.261 (168)	0.405 (261)	0.664 (428)	1.036 (668)	1.689 (1089)
Set Pressure, psig	SCFM	SCFM	SCFM	SCFM	SCFM	SCFM	SCFM	SCFM	SCFM	SCFM
15	6.0	30	68	130	299	524	813	1333	2081	3392
25	7.9	39	89	170	390	684	1062	1741	2717	4430
50	12	64	145	278	637	1117	1734	2842	4435	7231
75	17	89	203	388	889	1558	2418	3964	6185	10084
100	23	114	260	497	1141	1999	3102	5086	7935	12937
150	33	165	375	717	1644	2881	4470	7329	11435	18644
200	43	216	490	937	2148	3762	5838	9572	14936	24350
250	53	266	605	1156	2651	4644	7207	11816	18436	30056
300	63	317	719	1376	3154	5526	8575	14059	21936	35763
400	83	419	949	1815	4161	7290	11312	18546	28936	47175
500	104	520	1179	2254	5168	9053	14048	23032	35936	58588
750	154	773	1753	3352	7685	13462	20890	34249	53437	87119
890	183	915	2075	3967	9095	15931	24721	40530	63238	103097
1000	205	1027		4450	10202	17871	27731	45466	70938	115651
1500	306	1533		6646	15236	26689	41414	67899	105939	172714
2000	408	2040		8842	20270	35507	55097	90332	140941	229777
2500	509	2547		11038	25304	44325	68780	112766	175942	286840
2700	550	2750		11917	27318	47852	74253	121739	189943	309666
2750	560	2800		12136	27821	48734	75622	123982	193443	
3000	610	3054		13234	30338	53143	82463	135199		
3500	712	3561		15430	35372	61961	96146	157633		
3705	753	3768		16331	37436	65576	101756	166830		
4000	813	4067		17627	40406	70779	109829			
4072	828	4140		17943	41131	72048	111799			
4292	872	4363		18909	43346	75928	117820			
5000	1016	5081		22019	50474		137195			
5774	1173	5865		25418	58267					
6000	1219	6094		26411						
7000	1421	7108		30803						
8000	1624	8122		35195						
9000	1827	9135		39587						
9612	1951	9755		42275						
9944	2018	10092								
10313	2093									

**F88 FLOW CAPACITIES:**  
 10% Overpressure, 0 BP, 60 °F, Z=1.0, MW=29

# AIR

Orifice Size:	- 3	- 4	- 8	- G	- J
Orifice Area, in <sup>2</sup> (mm <sup>2</sup> ):	0.065 (41.9)	0.116 (74.8)	0.261 (168)	0.663 (428)	1.690 (1090)
ASME Discharge Coeff. K <sub>d</sub> :	0.889 <sup>1</sup>	0.878 <sup>1</sup>	0.878 <sup>1</sup>	0.847 <sup>1</sup>	0.875 <sup>1</sup>
Set Pressure, psig	SCFM	SCFM	SCFM	SCFM	SCFM
50	73	130	292	717	1888
60	85	150	338	830	2186
70	97	171	385	943	2484
80	108	191	431	1056	2782
90	120	212	477	1169	3080
100	132	232	523	1283	3378
150	190	335	754	1848	4868
200	248	438	985	2414	6358
300	364	643	1447	3546	9339
400	481	848	1909	4678	12319
500	597	1053	2370	5810	15299
1000	1180	2080	4680	11468	30200
2000	2344	4132	9298	22786	60003
2700	3160	5569	12531	30708	80865
3000	3509	6185	13917	34104	
3705	4330	7632	17173	42083	
4000	4673	8238	18535		
4292	5014	8837	19884		

<sup>1</sup> Equivalent K<sub>d</sub> shown. ASME certified value is "slope" (on air only) as follows:  
 F88-3: 1.06 scfm / psia  
 F88-4: 1.87 scfm / psia  
 F88-8: 4.20 scfm / psia  
 F88-G: 10.3 scfm / psia  
 F88-J: 27.1 scfm / psia

Capacity equation with "slope" factor:  $V = (\text{slope}) \bullet (\text{set pressure} + 10\% + 14.7)$   
 where V = capacity in scfm

See F84L & F88 Liquid Service catalog for F88 sizing and capacities on liquid.

**F88 FLOW CAPACITIES:**  
 10% Overpressure, 0 BP, 60 °F, Z=1.0, MW=32

# OXYGEN

Orifice Size:	- 3	- 4	- 8	- G	- J
Orifice Area, in <sup>2</sup> (mm <sup>2</sup> ):	0.065 (41.9)	0.116 (74.8)	0.261 (168)	0.663 (428)	1.690 (1090)
ASME Discharge Coeff. K <sub>d</sub> :	0.889 <sup>1</sup>	0.878 <sup>1</sup>	0.878 <sup>1</sup>	0.847 <sup>1</sup>	0.875 <sup>1</sup>
Set Pressure, psig	SCFM	SCFM	SCFM	SCFM	SCFM
50	70	123	278	682	1797
60	81	143	322	790	2081
70	92	162	366	898	2365
80	103	182	410	1005	2648
90	114	202	454	1113	2932
100	125	221	498	1221	3216
150	181	319	718	1760	4634
200	236	416	938	2298	6053
300	347	612	1377	3376	8890
400	458	807	1817	4453	11727
500	569	1003	2257	5531	14564
1000	1123	1980	4455	10918	28750
2000	2232	3934	8852	21692	57121
2700	3008	5302	11929	29234	76981
3000	3340	5888	13248	32466	
3705	4122	7265	16348	40061	
4000	4449	7842	17645		
4292	4773	8412	18929		

<sup>1</sup> Equivalent K<sub>d</sub> shown. ASME certified value is "slope" (on air only) as follows:  
 F88-3: 1.06 scfm / psia  
 F88-4: 1.87 scfm / psia  
 F88-8: 4.20 scfm / psia  
 F88-G: 10.3 scfm / psia  
 F88-J: 27.1 scfm / psia

**F88 FLOW CAPACITIES:**  
 10% Overpressure, 0 BP, 60 °F, Z=1.0, MW=2

## HYDROGEN

Orifice Size:	- 3	- 4	- 8	- G	- J
Orifice Area, in <sup>2</sup> (mm <sup>2</sup> ):	0.065 (41.9)	0.116 (74.8)	0.261 (168)	0.663 (428)	1.690 (1090)
ASME Discharge Coeff. K <sub>d</sub> :	0.889 <sup>1</sup>	0.878 <sup>1</sup>	0.878 <sup>1</sup>	0.847 <sup>1</sup>	0.875 <sup>1</sup>
Set Pressure, psig	SCFM	SCFM	SCFM	SCFM	SCFM
50	281	496	1117	2738	7211
60	326	575	1293	3170	8349
70	370	653	1470	3602	9487
80	415	731	1646	4034	10625
90	459	810	1822	4467	11763
100	504	888	1999	4899	12901
150	726	1280	2881	7060	18591
200	948	1672	3762	9221	24281
300	1393	2456	5526	13542	35661
400	1838	3240	7290	17864	47042
500	2283	4023	9053	22186	58422
1000	4506	7942	17871	43794	115324
2000	8953	15781	35507	87012	229128
2700	12066	21267	47852	117264	308790
3000	13400	23619	53143	130229	
3705	16535	29145	65576	160697	
4000	17847	31457	70779		
4292	19146	33746	75928		

<sup>1</sup> Equivalent K<sub>d</sub> shown. ASME certified value is "slope" (on air only) as follows:  
 F88-3: 1.06 scfm / psia  
 F88-4: 1.87 scfm / psia  
 F88-8: 4.20 scfm / psia  
 F88-G: 10.3 scfm / psia  
 F88-J: 27.1 scfm / psia

# PART NUMBERING

**F80 Series**

**S 8 5 J E - 0 2 R F 2 - 0 3 R F 1 - C S - S S - V T N**

**Options:**  
 N = NACE trim  
 L = Lift lever  
 S = Short NPT inlet (-4/-6/-8)  
 E = Electropolished inlet  
 [Repeat code for outlet]  
 DR = Dresser dims.  
 W = F80M with whistle  
 Z = additional welded fitting(s)

**Seals:**  
 T = Teflon / PTFE (standard)

**Seat:**  
**O-ring (F85)**      **Plastic (F84, F88)**  
 B = Buna-N      T = Teflon / PTFE  
 V = Viton (A)      K = Kel-F / PCTFE  
 E = EPR / EPDM      W = Polyimide / Vespel<sup>2</sup>  
 U = Polyurethane      P = PEEK  
 Y = HNBR  
 H = AED Viton  
 X = Perfluoroelastomer<sup>1</sup>

**Trim material:** See "Body material" below, or  
 SM = SS + Monel

**Body material:**  
 BR = Brass      N5 = Inconel 625  
 CS = Standard carbon steel      N0 = Inconel 600  
 CL = Low-temperature CS      6M = 6 Mo (254 SMO)  
 SS = 316 SS / CF8M      MO = Monel  
 SL = 316L SS / CF3M      C3 = LC3 CS  
 D4 = 22% Cr duplex SS      H2 = Hastelloy C / C22  
 D6 = 25% Cr duplex SS      H6 = Hastelloy C276

**Outlet size / connection type / rating:** See "Inlet" data below

**Inlet rating:**  
 0 = Threaded / Grayloc / VCR / etc.  
 1 = 150#      3 = 600#      5 = 1500#  
 2 = 300#      4 = 900#      6 = 2500#

**Inlet connection type:**  
 MN = Male NPT      RF = RF flange (ASME)      EF = RF flange (metric)  
 FN = Female NPT      RJ = RTJ flange (ASME)      EJ = RTJ flange (metric)  
 FM = Female MS/AS5202      GR = Grayloc hub      SW = socket weld  
 FS = Female SAE J1926/1      ST = Small tongue (T&G)      BW = butt weld  
 MS = Male SAE J1926/2      MV = Male VCR      BP = BSPP thread  
 TC = coned & threaded      FV = Female VCR      S2 = SAE J518 Code 62 flange

**Inlet size:**  
 14 = 1/4"    05 = 1/2"    91 = 9/16"    15 = 1-1/2"    25 = 2-1/2"    04 = 4"  
 38 = 3/8"    34 = 3/4"    01 = 1"      02 = 2"      03 = 3"      06 = 6"

**Body size:**  
 M = Micro      B = B body      E = E body (std. bonnet)  
 H = Micro, HP block      C = C body      X = XL bonnet (D or E)  
 P = Micro, 2-piece      D = D body (std. bonnet)

**Model (84 = F84; 85 = F85; 88 = F88) + Orifice size**

S = Spring-operated valve

<sup>1</sup> If not specified, Kalrez (Code Z), Chemraz (C), Perlast (M), or similar grade will be used.  
<sup>2</sup> Equivalent PI or PAI (e.g., Duratron) may be substituted for Vespel.



## SAMPLE SPECIFICATION SHEET

Please include data as shown in the following table when contacting Flow Safe or their representatives regarding a relief valve application:

SERVICE CONDITIONS	Quantity	each
	Valve identification / tag number(s)	
	Delivery time	weeks
	Service media / fluid state	
	Molecular weight (gases)	
	Compressibility factor (gases)	
	Specific heat ratio (gases)	
	Specific gravity (liquids)	
	Viscosity (liquids)	
	Required capacity	scfm (Nm <sup>3</sup> /hr) lb/hr (kg/hr) gpm (lpm)
	Set pressure	psig barg kPag
	Allowable overpressure	% or psi / bar / kPa
	Backpressure	psig barg kPag
	Required blowdown	% or psi / bar / kPa
	Relieving temperature (at relief valve location)	°F or °C
	Normal operating temperature (at relief valve location)	°F or °C
System design temperature	°F or °C	
Required cleanliness level		
VALVE SELECTION	Body / bonnet material	
	Trim (wetted internals) material	
	Seat and seal material	
	Size and ASME Class for inlet / outlet	
	Flange facing, inlet/outlet	
	Special inlet / outlet	
	Orifice area calculated / selected	
	Valve part number (optional - see p. 26)	

# Experts in Soft-Seated Technology



**F7000/8000 Series**  
Pilot-Operated Relief Valve -  
ASME VIII



**F84L/88 Series**  
Liquid Relief Valve - ASME VIII



**F70U Series**  
Unloader Valve



**F9000 Series**  
Liquid Surge Relief



**F70PR Series**  
Pilot-Operated Relief Valve - DOT

Leaders in "true" High Performance with  
commitment to value through:

- 24/7 service, repair, and support
- Soft seats offering unsurpassed tightness
- Large coefficients and orifice areas = Best capacities
- Backpressure-balanced without bellows
- ASME Sec. VIII, API, DOT, ISO 9001, CE, Marine class societies (e.g., DNV, BV)
- Trained representatives with solid factory support
- Quick-ship program through Flow Safe Supply



**FLOW SAFE**  
High Performance Safety Relief Valves

**YOUR AUTHORIZED  
REPRESENTATIVE**

Executive Office  
3865 Taylor Road  
Orchard Park, NY 14127  
(716) 662-2585  
(716) 662-2580 Fax

Houston Office  
10727 Tower Oaks Blvd.  
Houston, TX 77070  
(832) 678-2070  
(716) 662-2580 Fax

www.flowsafe.com  
Inquiries: info@flowsafe.com