

*“THE NEXT GENERATION”*

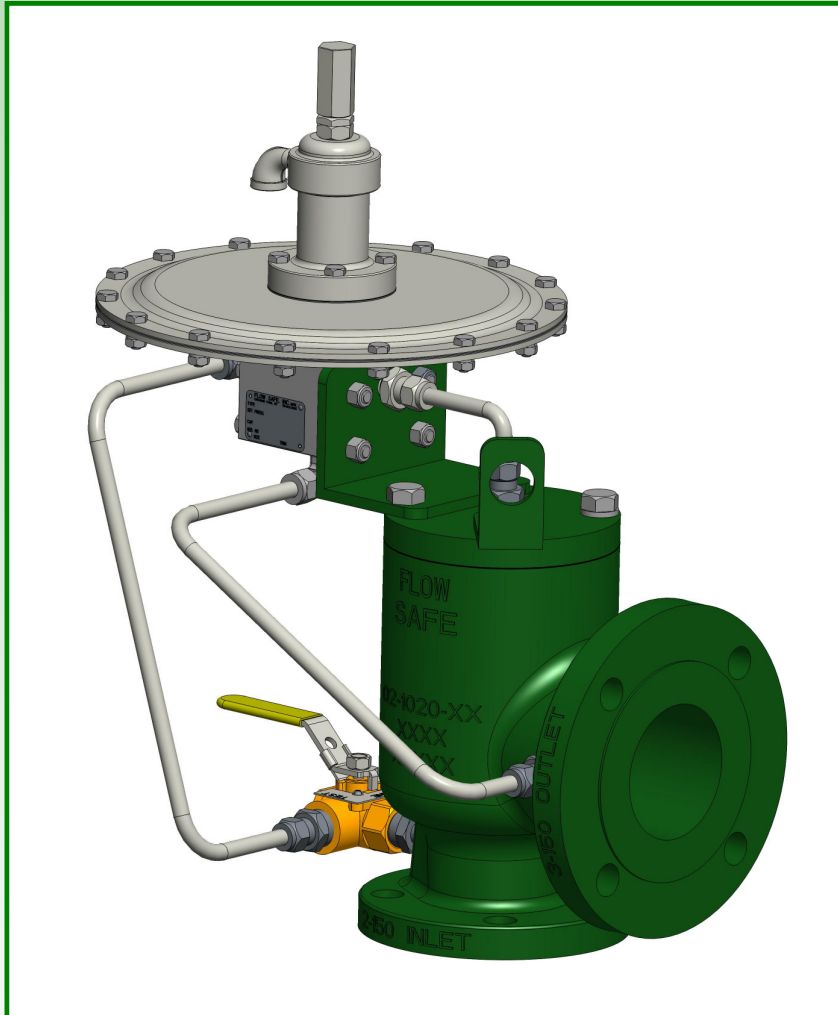

**FLOW SAFE**

*High Performance Safety Relief Valves*



# **F70PR Series**

## ***Pilot-Operated Safety Relief Valves***

# CONTENTS

<i>SECTION</i>	<i>PAGE</i>
Introduction and Features .....	2
Operation .....	3
Applications .....	4-5
Construction, HP Assembly .....	6-7
Construction, LP Assembly .....	8-9
Construction, F100 Pilot .....	10
Specifications .....	11
Accessories and Options .....	12-13
Sizing .....	14-16
Capacities .....	17
Part Numbering .....	18
How to Order .....	19
Other Flow Safe Products .....	Back Cover

The policy of FLOW SAFE and its authorized assemblers is a commitment to value through:

- Environmentally compatible products
- Cost-efficient design with minimal parts
- Quality products, readily available
- Flexibility to meet unique customer needs
- “No-hassle” service

# INTRODUCTION AND FEATURES

Today’s natural gas and process industries require leak-tight valves to reduce emissions, save product, and minimize horsepower requirements.

The **F70PR** Series “High Performance Pilot Operated Pressure Relief Valves” accomplish bubble-tight seating with accurate and consistent operational characteristics.

**F70PR** design features include:

- Modulating valve action (less product loss)
- Elastomeric seat and seals
- Repeatable bubble-tight seating
- Rugged, simple, and efficient design
- Superior flow capacities (independently verified)
- 10 "wc to 285 psig set pressure range
- -65 to 400 °F service temperature range
- DOT (49CFR192.199) compliance
- Easy and economical installation
- Inline maintenance capability
- Pilot exhaust to main valve (standard)
- Direct-mount pilot on 4" size and larger
- Discharge drain plug (standard)
- Available field test connection / valve
- Lift brackets — 2x3 and larger (standard)

# OPERATION

## F70PR Series

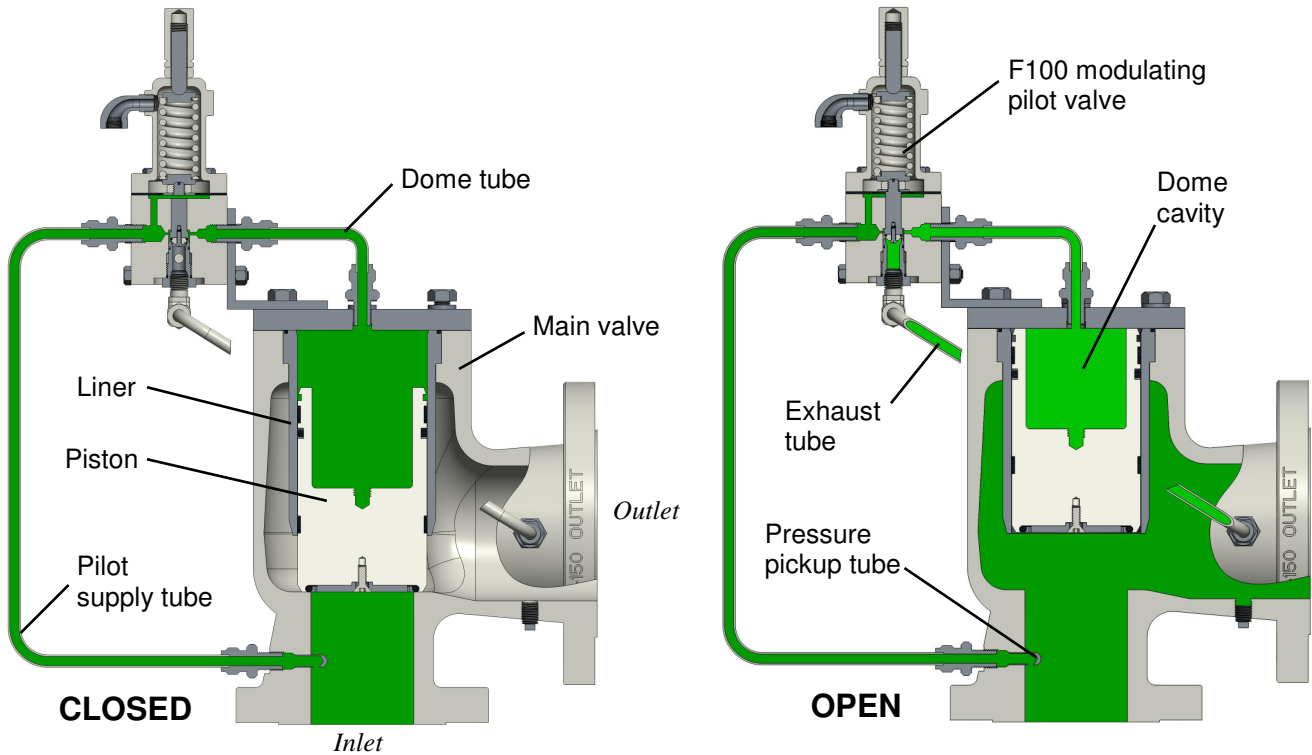

System pressure is sensed from the valve inlet, through the modulating pilot valve, to the dome cavity of the main valve. At the designated set pressure, the pilot valve reduces the dome pressure proportional to demand, and allows the piston to lift. Once system pressure is relieved, the pilot valve closes, allowing the dome to repressurize and the main valve piston to close.

When the piston is closed, dome pressure acts on an area at the top piston seal that is greater than the seat area, creating a net downward force to keep the piston tightly seated.

The **F70PR** uses an elastomeric seat on the piston to achieve bubble-tight seating. A dynamic piston seal prevents any leakage from the dome to the discharge. Wear rings on the piston prevent any metal-to-metal contact, and help to provide smooth, consistent, and repeatable operation.

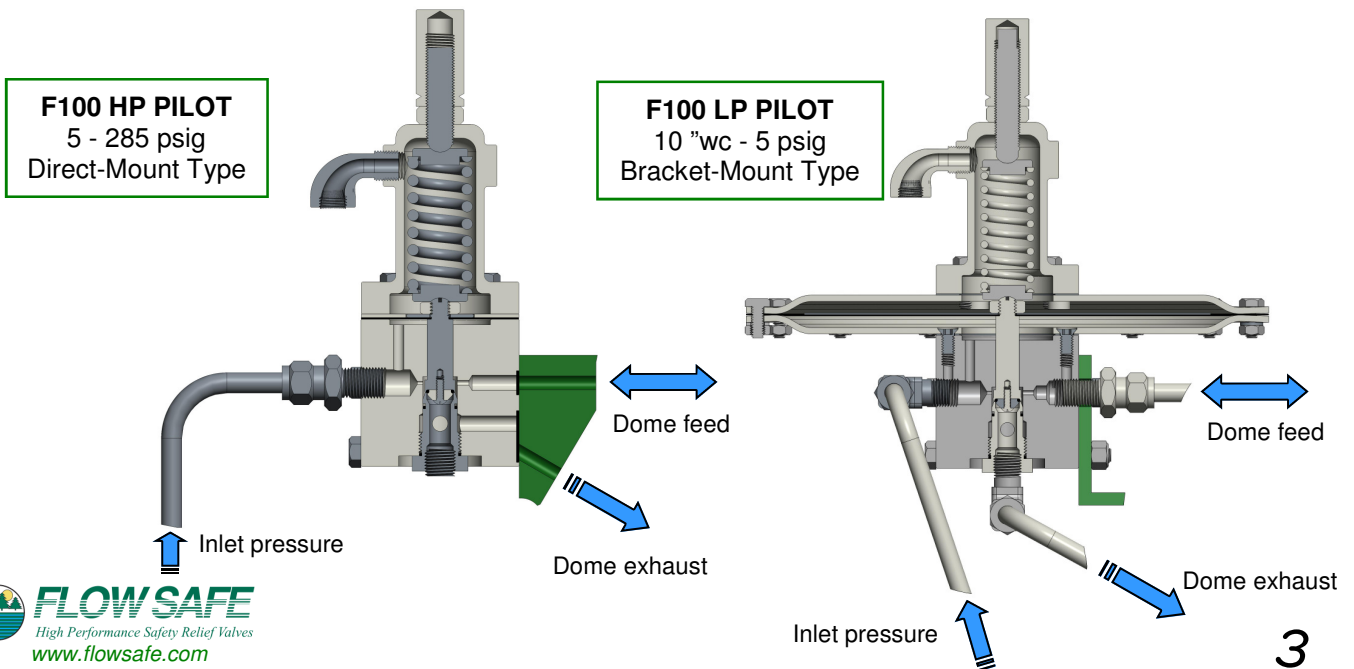

## Natural Gas

The **F70PR** pressure relief valve provides overpressure safety protection for natural gas distribution or transmission applications, with the ability to handle large volumes and provide consistent, leak-tight shut-off before and after a system upset.

The **F70PR** is designed to be repeatedly cycled at full pressure throughout its acceptable range of temperatures. It is ideal for systems that require overpressure protection, and utilizes modulating action to improve process efficiency and reduce product loss. The **F70PR's** F100 Series pilot valve is bubble-tight to the set point upon opening, and reseats by 5% below set point, allowing the user to operate close to the nameplate set pressure. A maximum of 5% overpressure is required to fully open the main valve.

The **F70PR** is ideal for city gate, end of line, single regulator-relief and meter station protection. It is also the safest and most economical choice when using it in conjunction with a monitor regulator system for full capacity protection.

- Regulator operating pressure is close to MAOP
- A high cycling rate exists
- A long service life is required
- Minimal product loss is important
- Reduced installation and maintenance time is desirable
- DOT compliance is required
- Fail open design

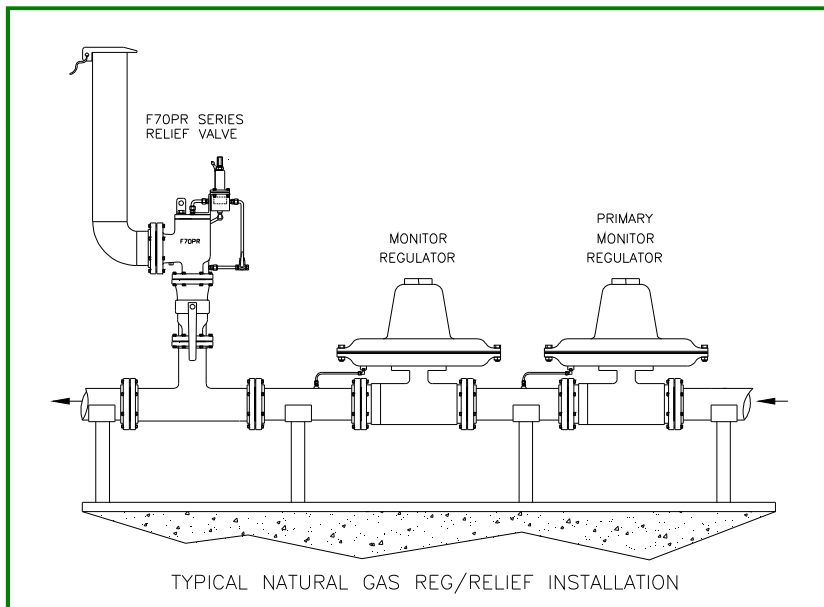

In all applications, the end user should consider preventing the freezing of liquids within the valve which may, under certain conditions, cause erratic performance or valve failure.

## Compare the Safety & Value !

*Value of ownership* is offered by utilizing the **F70PR**. Easy installation and inline maintenance is offered by the right angle body style design. Quick-ship same-day repair kits available.

High flow rates provide, in many cases, one inlet size smaller than equivalent capacity pilot-operated regulator / relief valves.

The Flow Safe **F70PR** features:

- √ Simple design
- √ Reliable operation
- √ Easy Installation
- √ Easy, inline serviceability
- √ Superior flow capacities
- √ Self-draining
- √ Easy field testing
- √ ESD (emergency shutdown) capability available with use of remote blowdown option — See Page 13

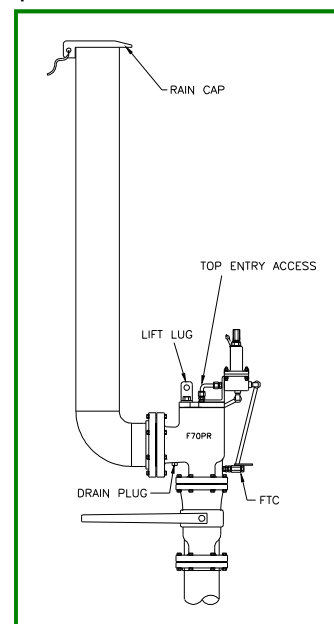

## Process Industries

The **F70PR** pressure relief valve is a superior choice to protect industrial process applications at lower (non-Code) set pressures because of the valve's heavy-duty, low-profile body design.

The **F70PR**'s ability to flow high volumes of gas or liquid allows for a smaller valve size than traditional relief valves to get the job done. Smaller valves are not only less expensive but also require smaller piping and isolation valving, and associated connections, both on the inlet and on the outlet.

Remote pressure pickup, unloading, and field testing are available options for the **F70PR** Series that allow the operator greater versatility in the operation and servicing of this valve. See Page 12 for more details.

## Positive Displacement Blowers - Relief and Unloading

The design technology of the **F70PR** offers, for the first time, a solution for this very demanding, high-cycle, high-vibration/pulsation service. Due to the robust piston design, the **F70PR** can handle the inherent vibrations and pulsations of these blower systems. The welded-in stainless steel seating surface, piston wear rings, and the high L / D piston construction allow the valve the ability to operate reliably for an extended period of time.

The installation of a solenoid valve to the dome of the **F70PR** main valve allows unloading by being able to open the valve at any point below set pressure. Upon startup, to reduce downstream load, the **F70PR** provides atmospheric reference. When the blower stage is run, the **F70PR** reverts back to the relief mode with the solenoid valve closed.

By unloading upon startup, less load is applied to motors — offering protection, extending motor life and, in some cases, reducing the required motor horsepower. Expensive butterfly valves and high-maintenance actuators can be avoided when replaced with the **F70PR** relief and unloader option.

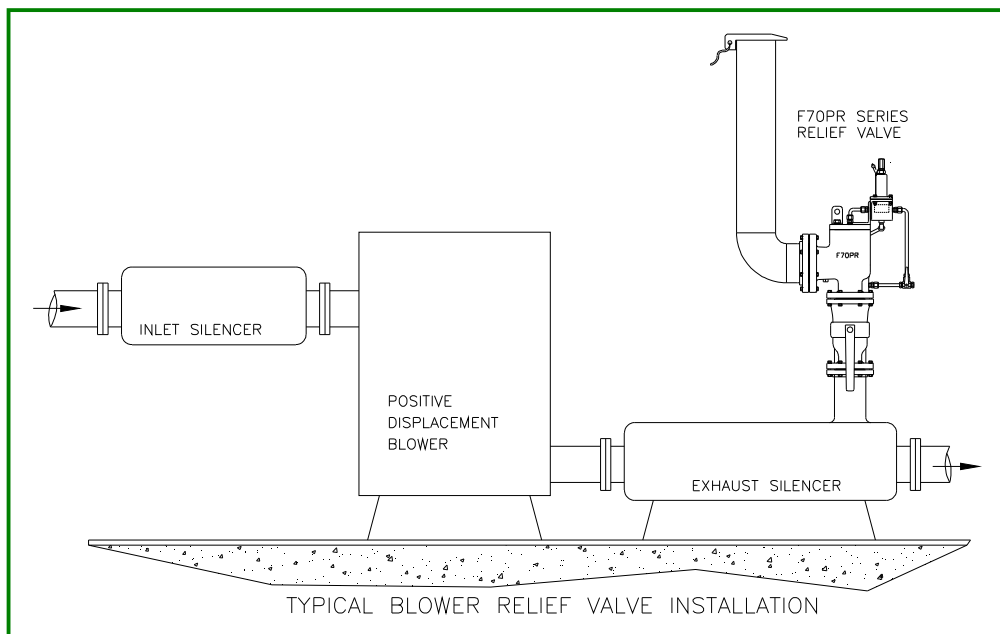

# CONSTRUCTION - HP Assembly

**F70PR Series**

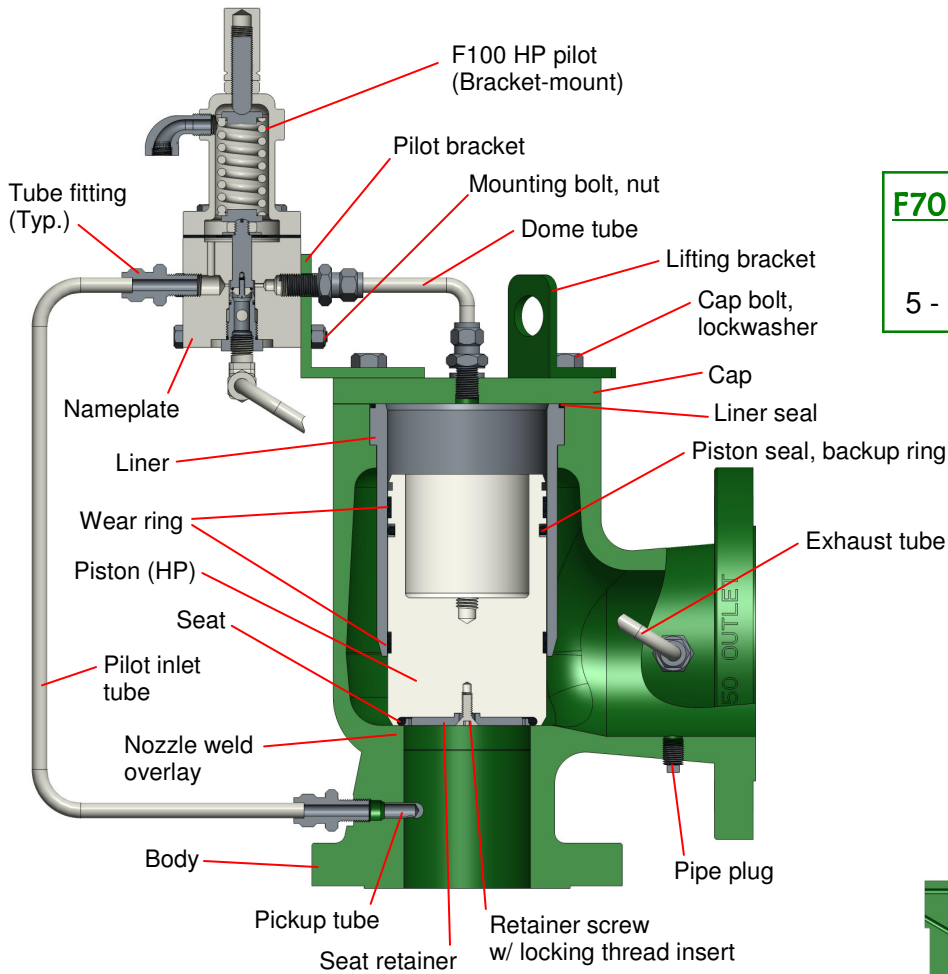

**F70PR High Pressure Assembly**  
**2x3 and 3x4 Sizes**  
 5 - 285 psig with F100 HP Pilot

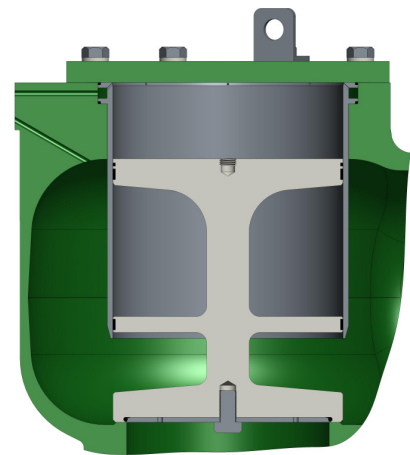

**Low-Dome Piston**  
 12x16 - Standard  
 10x12 - Optional

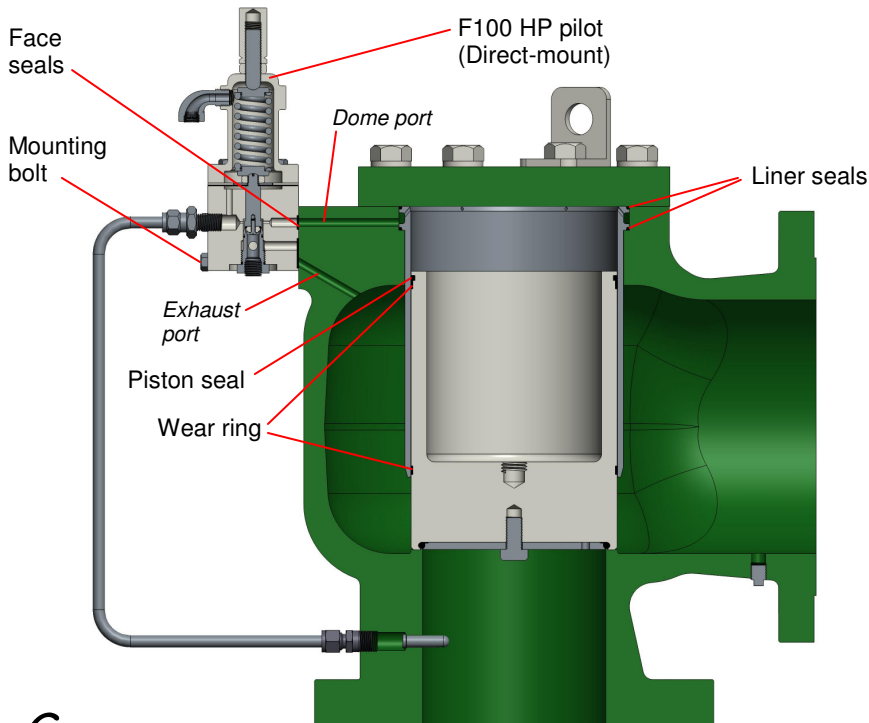

**F70PR High Pressure Assembly**  
**4x6 thru 12x16 Sizes**  
 5 - 285 psig with F100 HP Pilot  
 2 - 4.9 psig with F100 LP Pilot

## Parts List - HP Assembly

Part Name	Materials of Construction	
	Standard Trim	Stainless Steel (S1) Trim
Body	A216 WCB <sup>1</sup>	A216 WCB <sup>1</sup>
Cap	6061 Aluminum or CS	6061 Aluminum or CS
Liner	Carbon steel (coated) <sup>2</sup>	Carbon steel (coated) <sup>2</sup>
Piston	Aluminum—356.0 cast or 6061	A479 316 or A351 CF8M
Seat retainer	6061 Aluminum	316 SS
Retainer screw	316 SS	316 SS
Piston seal	Elastomer <sup>3</sup>	Elastomer <sup>3</sup>
Backup ring	PTFE	PTFE
Liner seal	Elastomer <sup>3</sup>	Elastomer <sup>3</sup>
Wear ring	Graphite-filled PTFE	Graphite-filled PTFE
Seat	Elastomer <sup>3</sup>	Elastomer <sup>3</sup>
Nozzle weld overlay	309 SS	309 SS
Pickup tube	A479 316/316L	A479 316/316L
Cap bolt	SAE Gr. 5	SAE Gr. 5
Lockwasher	316 SS	316 SS
Locking thread insert	304 SS	304 SS
F100 HP pilot	Aluminum, SS trim & spring	Aluminum, SS trim & spring
Face seals	Elastomer <sup>3</sup>	Elastomer <sup>3</sup>
Tubing	316 SS	316 SS
Tube fittings	Carbon steel (plated)	Carbon steel (plated)
Pipe plug	316 SS	316 SS
Nameplate	316 SS	316 SS
Pilot, lifting brackets	A36	316 SS
Mounting bolts, nuts	304 or 316 SS	304 or 316 SS
Dome spring (optional, not shown) <sup>4</sup>	302/304 SS	302/304 SS
Field test valve (optional, not shown) <sup>5</sup>	Brass	Brass

Materials are subject to change without notice.

Contact Flow Safe for availability of materials not shown.

<sup>1</sup> ASTM B26 356.0 cast aluminum for 1-1/2 x 2 size

<sup>2</sup> 316 SS liner standard in 1-1/2 x 2 size

<sup>3</sup> Buna-N standard; see p. 11 for other material options.

<sup>4</sup> Spring helps keep piston seated in shipping and during system startup

<sup>5</sup> See p. 8 for typical position of field test connection

**F70PR High Pressure Assembly**  
1-1/2x2 Size

5 - 285 psig with F100 HP Pilot

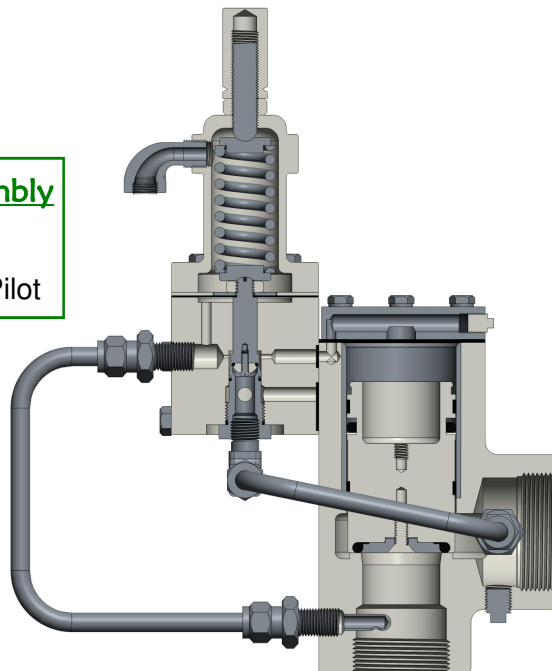

# CONSTRUCTION - LP Assembly

**F70PR Series**

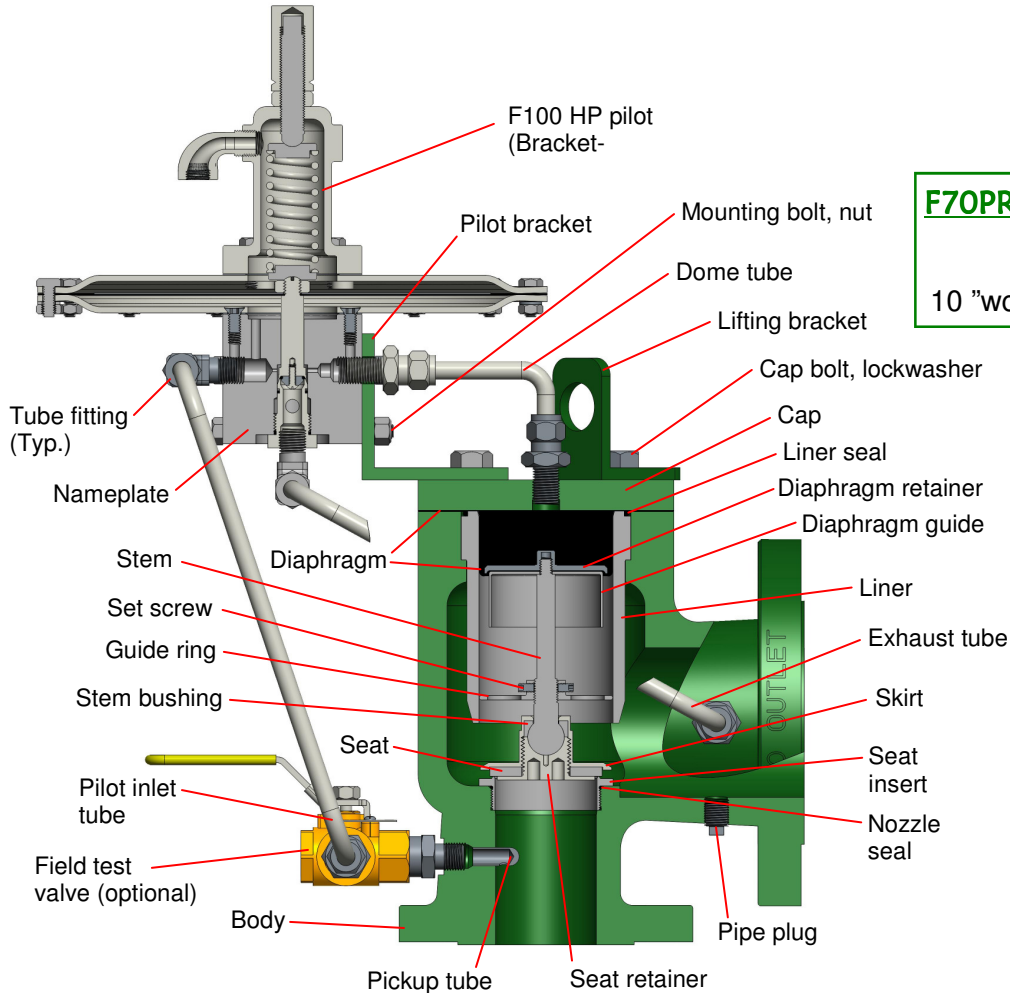

**F70PR Low Pressure Assembly**  
**2x3 and 3x4 Sizes**  
 10 "wc - 5 psig with F100 LP Pilot

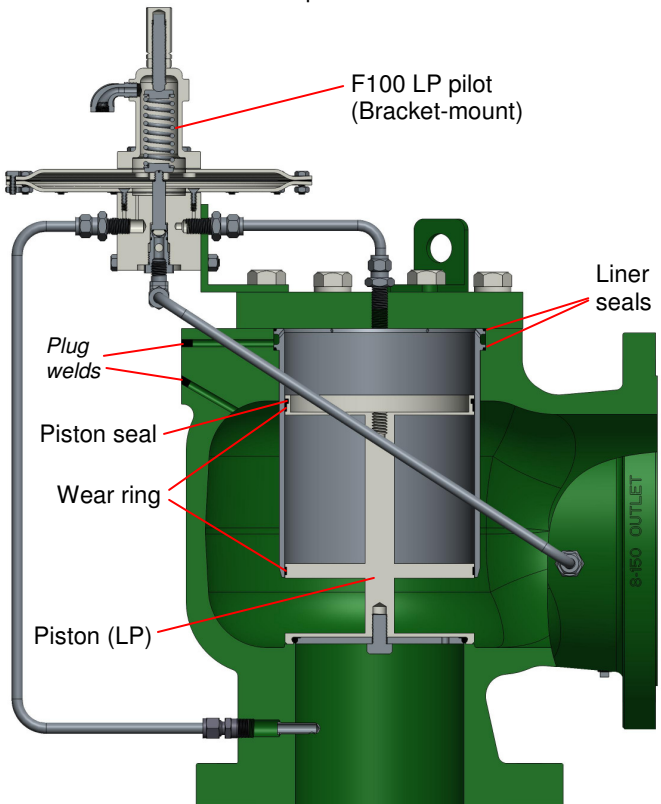

**F70PR Low Pressure Assembly**  
**4x6 thru 8x10 Sizes**  
 10 "wc - 2 psig with F100 LP Pilot  
 2 - 4.9 psig with F100 LP Pilot + HP Piston  
 2 psig minimum for 10x12 and 12x16

## Parts List - LP Assembly

Part Name	Materials of Construction
	Standard Trim
Body	A216 WCB <sup>1</sup>
Cap	6061 Aluminum or CS
Liner	Carbon steel (coated) <sup>2</sup>
Liner seal	Elastomer <sup>3</sup>
Diaphragm guide, retainer	6061 Aluminum
Diaphragm	Buna-N
Stem	6061 Aluminum
Set screw	302 SS
Guide ring	6061 Aluminum
Skirt	6061 Aluminum
Stem bushing	PEEK
Seat retainer	6061 Aluminum
Seat	Buna-N / Neoprene / PVC polymer
Seat insert	316 SS
Nozzle seal	Elastomer <sup>3</sup>
Pickup tube	A479 316/316L
Cap bolt	SAE Gr. 5
Lockwasher	316 SS
Locking thread insert	304 SS
F100 LP pilot	Aluminum, SS trim & spring
Tubing	316 SS
Tube fittings	Carbon steel (plated)
Pipe plug	316 SS
Nameplate	316 SS
Pilot, lifting brackets	A36
Mounting bolts, nuts	304 or 316 SS
Field test valve (optional)	Brass

Materials are subject to change without notice. Contact Flow Safe for availability of materials not shown.

<sup>1</sup> ASTM B26 356.0 cast aluminum for 1-1/2 x 2 size

<sup>2</sup> 316 SS liner standard in 1-1/2 x 2 size

<sup>3</sup> Buna-N standard; see p. 11 for other material options.

### F70PR Low Pressure Assembly 1-1/2x2 Size

10 "wc - 4.9 psig with F100 LP Pilot

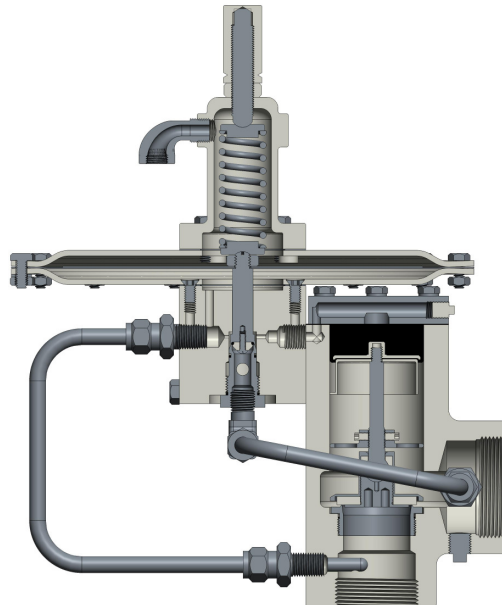

# CONSTRUCTION - F100 PILOT

**F70PR Series**

Part Name	Materials of Construction	
	Standard Trim	Stainless Steel (S3) Trim
Body	6061 Aluminum	316 SS
Bonnet	6061 Aluminum	316 SS
Spring	302/304/17-7 SS	302/304/17-7 SS
Spring washer	316 SS	316 SS
Seat, seals, O-rings	Elastomer <sup>1</sup>	Elastomer <sup>1</sup>
Pressure adjustment (PA) screw	316 SS	316 SS
Lock nuts	316 SS	316 SS
Cap	6061 Aluminum	6061 Aluminum
Bolt, bonnet bolt	304 or 316 SS	304 or 316 SS
Nut	304 or 316 SS	304 or 316 SS
Spindle	316 SS	316 SS
Nozzle	316 SS	316 SS
Retainer	316 SS	316 SS
Retainer screw	316 SS	316 SS
Spacers	6061 Al or 304 SS	304 SS
Diaphragm housing	304 SS	304 SS
Support plate	6061 Aluminum	304 SS
Diaphragm	Elastomer <sup>1</sup>	Elastomer <sup>1</sup>
Gasket	Elastomer <sup>1</sup>	Elastomer <sup>1</sup>
SH cap screw	316 SS	316 SS
Self-clinching fastener	302 or 304 SS	302 or 304 SS
Pipe plug	316 SS	316 SS
Inlet screen	316 SS	316 SS
Vent / bug screen	Plastic	Plastic

Materials are subject to change without notice. Contact Flow Safe for availability of materials not shown.  
<sup>1</sup> Buna-N standard; see p. 11 for other material options.  
 PTFE/FEP diaphragm requires use of Buna-N or Viton gasket on top.

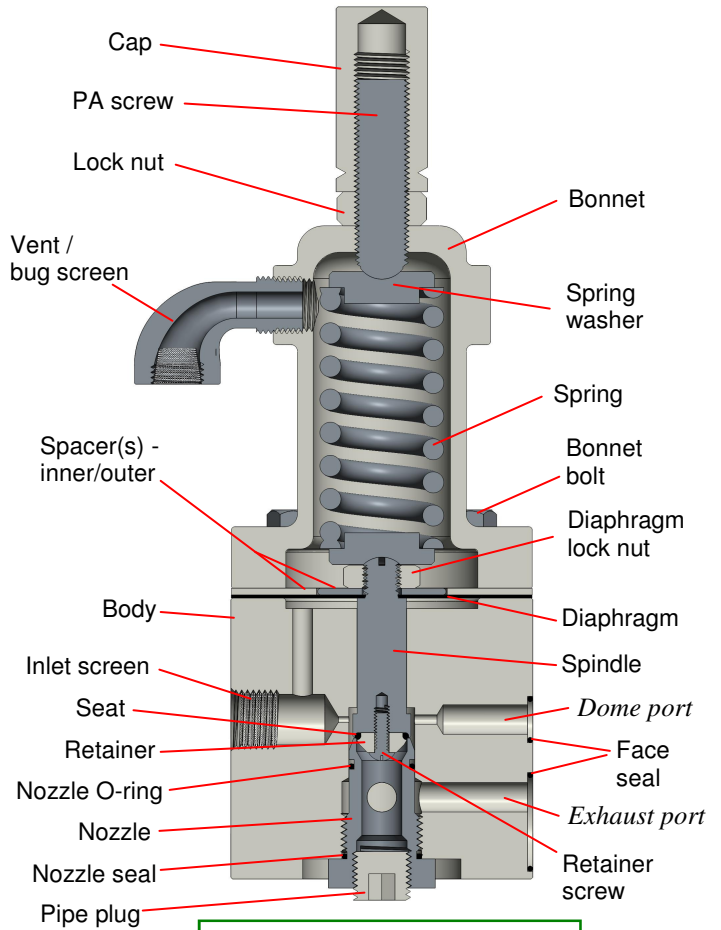

**F100 High Pressure Pilot**  
 Direct-mount type shown  
 5 - 285 psig

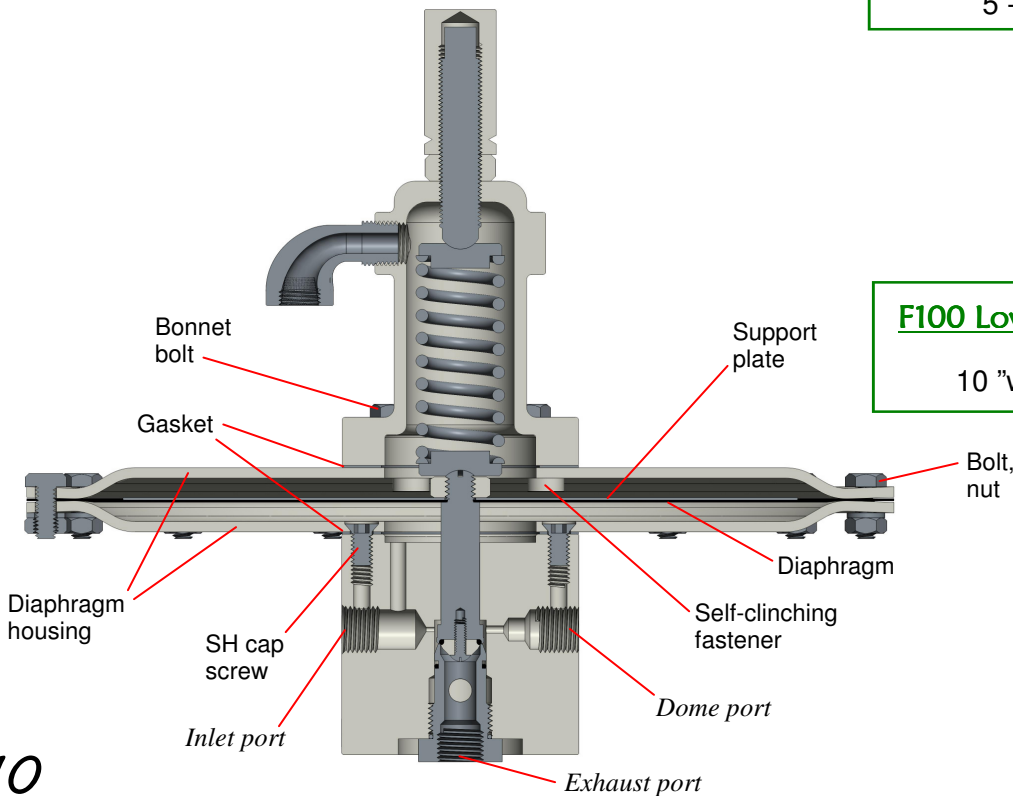

**F100 Low Pressure Pilot**  
 10 "wc - 4.9 psig

# SPECIFICATIONS

# F70PR Series

## General Data

Set pressure range, Low Pressure (LP)	1-1/2x2 thru 8x10: 10 in. w.c. to 4.9 psig (0.025 to 0.34 barg)
	10x12 and 12x16: 2 to 5 psig (0.14 to 0.34 barg)
Set pressure range, High Pressure (HP)	5 to 285 psig (0.34 to 19.6 barg)
Service temperature range (continuous)	-65 °F (-54 °C) to 400 °F (204 °C)
Materials of construction	See pages 7, 9, and 10
<b>Seat / Seal / Pilot Diaphragm Material</b>	Continuous Process Temperature, °F (°C)
	Min. Max.
Buna-N	-30 (-34) 275 (135)
Fluorocarbon: Viton ® or equal	-30 (-34) 400 (204)
Ethylene propylene (EPR / EPDM)	-65 (-54) 325 (163)
Perfluoroelastomer: Kalrez ®, Chemraz ®, or equal (Seat and seals only)	0 (-18) 525 (274)
PTFE / FEP (Diaphragms only)	-400 (-240) 400 (204)

Viton and Kalrez are registered trademarks of E.I. Du Pont de Nemours and Co. or affiliates. Chemraz is a registered trademark of Greene, Tweed.

## Dimensions

Inlet Connection	Outlet Connection	Orifice area, in <sup>2</sup> (mm <sup>2</sup> )	Dimensions, in (mm) <sup>1</sup>				Approx. weight, lb (kg)
			A	B	C, approx.	D, approx.	
1-1/2" FNPT	2" FNPT	1.770 (1142)	2.75 (70)	3.00 (76)	12.6 (320)	12.0 (305)	15 (7)
2"-150#	3"-150#	3.365 (2171)	4.56 (116)	5.30 (135)	18.5 (470)	17.5 (445)	60 (27)
3"-150#	4"-150#	7.402 (4775)	5.70 (145)	7.00 (178)	21.5 (546)	18.5 (470)	85 (39)
4"-150#	6"-150#	11.43 (7374)	7.75 (197)	8.25 (210)	18.5 (470)	19.0 (483)	170 (77)
6"-150#	8"-150#	26.06 (16813)	9.44 (240)	9.50 (241)	23.0 (584)	22.0 (559)	270 (122)
8"-150#	10"-150#	45.66 (29458)	10.88 (276)	11.00 (279)	26.5 (673)	26.5 (673)	460 (209)
10"-150#	12"-150#	71.85 (46354)	11.63 (295)	13.00 (330)	27.5 (699)	31.0 (787)	775 (351)
12"-150#	16"-150#	111.87 (72174)	11.92 (303)	15.56 (395)	33.0 (838)	32.0 (813)	1100 (500)

<sup>1</sup> Contact Flow Safe for submittal drawing whenever specific dimensions are needed for construction.

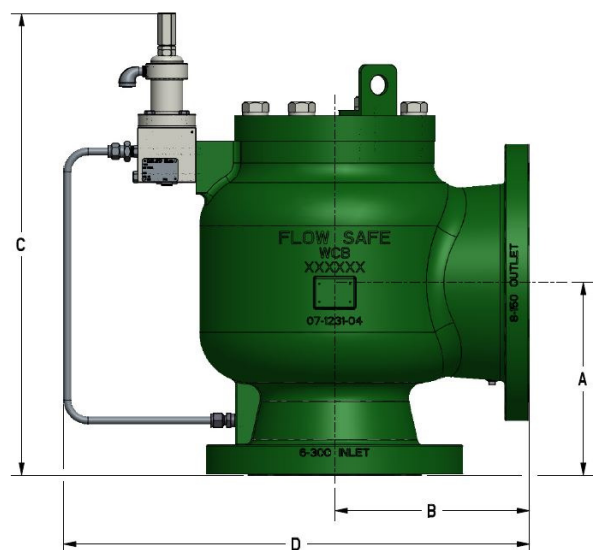
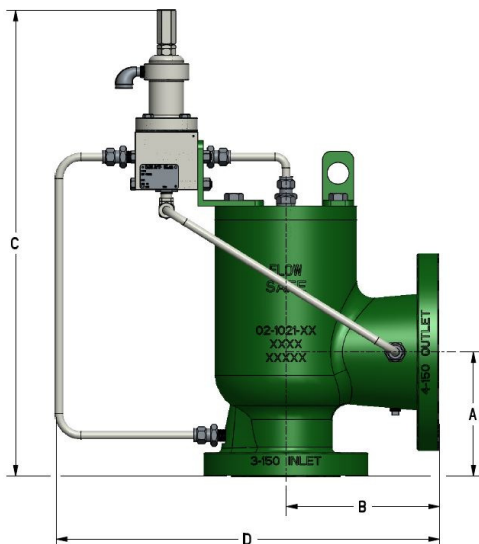

### FIELD TEST CONNECTION (P/N Code T)

The FTC is a 3-way valve that allows the user to verify set pressure while in service without relief valve removal. An external pressure source is connected to the open port of the FTC. With the FTC valve switched to the “test” position, the port from the main valve inlet is blocked and test pressure will be routed to the pilot. With the modulating F100 pilot, exhaust flow from the pilot can be detected in advance of the main piston opening. Once the field test procedure is completed, the FTC valve is switched back to the “online” position and the handle may be locked.

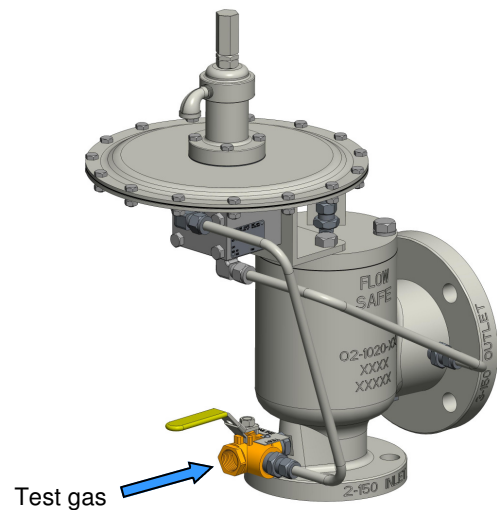

### INLET SUPPLY FILTER (P/N Code F)

A filter should be used for dirty applications to clean the supply fluid to the pilot, helping to ensure internal pressure communication. A drain plug on the filter is standard.

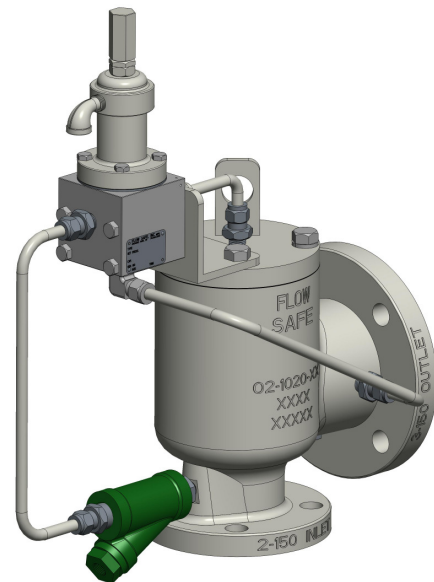

### CLOSED DOME TEE (P/N Code D)

This option allows for future mounting of a manual valve, solenoid valve, pressure gauge, or other instrumentation.

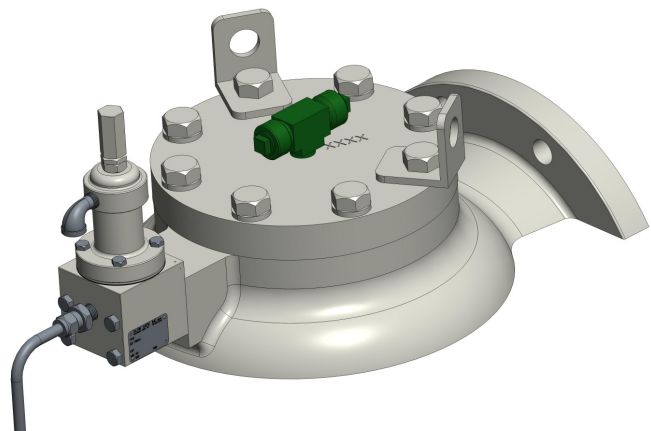

### MANUAL BLOWDOWN VALVE (P/N Code M)

This valve allows the operator to vent the main valve dome cavity and open the piston during an emergency or other operation, independently of the pilot reaching set pressure.

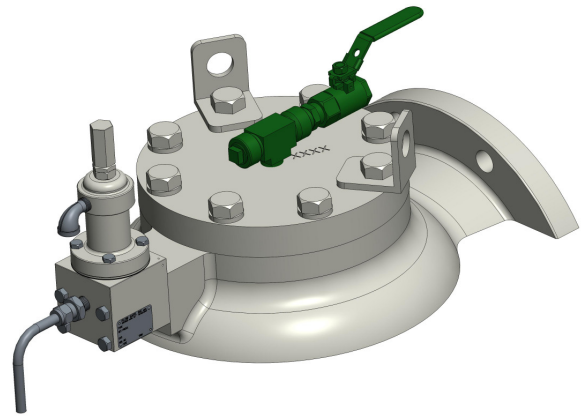

### REMOTELY OPERATED BLOWDOWN VALVE (P/N Code A or B)

This valve, located on the main valve cap, allows opening of the main valve without actuating the pilot. Opening the blowdown valve rapidly exhausts main valve dome pressure, allowing the piston to lift. Various arrangements of solenoid or pneumatic pilot valves, or air-actuated ball valves, may be used for emergency shutdown or other operation according to system needs. Use option code A for normally open solenoid valve and code B for a normally closed valve.

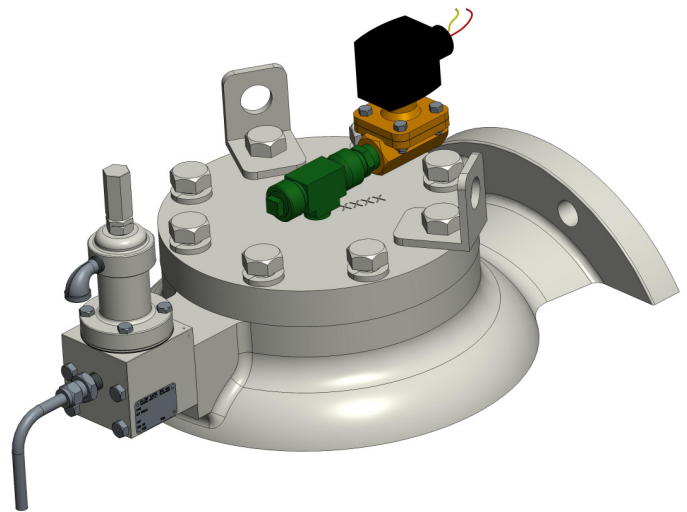

### BACKFLOW PREVENTER (P/N Code P)

This option prevents backflow from the outlet to the inlet, when the inlet is at a vacuum condition or when outlet pressure exceeds inlet pressure. For vacuum protection only, the pilot inlet check valve is all that is needed.

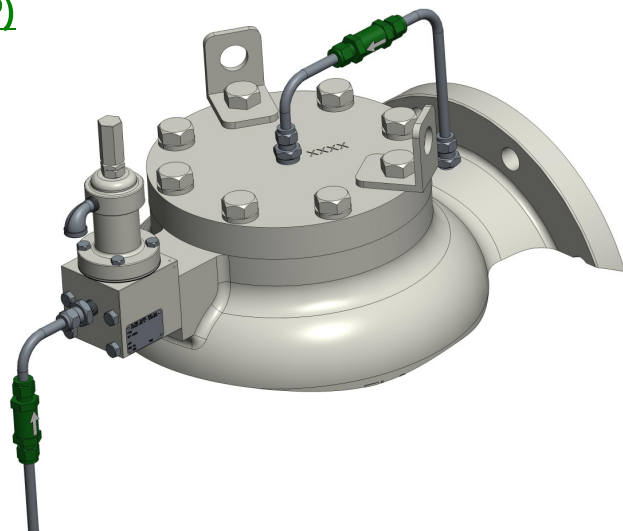

## SIZING FOR GAS & VAPOR SERVICE

Described below are criteria and equations used to calculate the flow capacities of **F70PR** Series relief valves on gas or vapor. Equations are based on API 520 Part I. Capacities for air and natural gas at various set pressures are tabulated on Page 17 for easy reference.

To size the F70PR relief valve for gas or vapor service, the following information is required:

- Required flow capacity
- Required set pressure
- Backpressure (pressure at valve outlet)
- Acceptable overpressure [10% or 3 psi per ASME Sec. VIII, or 5% per DOT installation practices]
- Operating pressure, to assure that it is below valve reseal pressure
- Gas properties, including molecular weight, specific heat ratio or gas constant, and compressibility factor

To select the required orifice size for a gas or vapor application, the below equations should be used. Depending on the gas, critical flow generally exists at pressures above 11 to 12 psig with zero backpressure, or at higher pressures where backpressure is less than approximately 50% of inlet pressure. If backpressure is less than or equal to  $P_{cf}$  in the following equation, critical flow will occur:

$$P_{cf} = P_1 \left[ \frac{2}{k+1} \right]^{\frac{k}{k-1}}$$

### Critical Flow

In US customary units:

$$A = \frac{V \sqrt{MTZ}}{6.32CK_dP_1K_bK_c}$$

- OR -

$$A = \frac{W}{CK_dP_1K_bK_c} \sqrt{\frac{TZ}{M}}$$

In SI units:

$$A = \frac{2.676V \sqrt{MTZ}}{CK_dP_1K_bK_c}$$

- OR -

$$A = \frac{W}{CK_dP_1K_bK_c} \sqrt{\frac{TZ}{M}}$$

### Subcritical Flow

In US customary units:

$$A = \frac{V}{4645F_2K_dK_c} \sqrt{\frac{MTZ}{P_1(P_1-P_2)}}$$

- OR -

$$A = \frac{W}{735F_2K_dK_c} \sqrt{\frac{TZ}{MP_1(P_1-P_2)}}$$

In SI units:

$$A = \frac{47.95V}{F_2K_dK_c} \sqrt{\frac{MTZ}{P_1(P_1-P_2)}}$$

- OR -

$$A = \frac{17.9W}{F_2K_dK_c} \sqrt{\frac{TZ}{MP_1(P_1-P_2)}}$$

- A = Required discharge orifice area, in<sup>2</sup> or mm<sup>2</sup>
- V = Required flow rate, scfm or Nm<sup>3</sup>/min
- W = Required flow rate, lb/hr or kg/hr
- K<sub>d</sub> = Rated discharge coefficient (See top of next page)
- C = Gas constant, dependent on specific heat ratio  $k = C_p/C_v$  (See table on p. 16)
- P<sub>1</sub> = Relieving pressure (set pressure plus overpressure plus atmospheric pressure), psia or kPaa
- P<sub>2</sub> = Backpressure, psia or kPaa
- P<sub>a</sub> = Inlet pressure + accumulation, psig
- K<sub>b</sub> = Backpressure correction factor, for balanced bellows valves only (otherwise, use 1.0)
- K<sub>c</sub> = Rupture disk correction factor: 1.0 with no disk, 0.9 with disk in combination
- M = Molecular weight at inlet relieving Conditions (See table on p. 16)
- T = Relieving temperature, °R (°F + 460) or °K (°C + 273)
- Z = Compressibility factor at inlet relieving conditions, 1.0 if unknown
- F<sub>2</sub> = Coefficient of subcritical flow; See figure on p. 16
- k = Specific heat ratio, C<sub>p</sub>/C<sub>v</sub> (See table on p. 16)
- P<sub>cf</sub> = Critical flow nozzle pressure

**See next page for gas sizing example.**

## SIZING FOR GAS & VAPOR SERVICE (cont'd)

Pressure Range, P <sub>a</sub> / Size	K <sub>d</sub>
10 in. w.c. - 5 psig (all sizes)	0.698
5 - 15 psig (1-1/2x2, 2x3, 3x4)	0.0084P <sub>a</sub> + 0.656
5 - 15 psig (all others)	0.0202P <sub>a</sub> + 0.597
15 - 30 psig (1-1/2x2)	0.00453P <sub>a</sub> + 0.714
15 - 30 psig (2x3, 3x4)	0.00253P <sub>a</sub> + 0.744
15 - 285 psig (all others)	0.900
30 - 285 psig (1-1/2x2)	0.850
30 - 285 psig (2x3, 3x4)	0.820

### GAS SIZING EXAMPLE

Service conditions: Set pressure = 60 psig; 5% overpressure; 10 psig backpressure  
 Natural gas at 80 °F; Compressibility factor = 0.95  
 Capacity required = 8,000 scfm  
 Assume F70PR series and associated discharge coefficient

Check critical flow pressure:

$$P_{cf} = P_1 \left[ \frac{2}{k + 1} \right]^{\frac{k}{k-1}}$$

$$= [(60)(1.05) + 14.7] \bullet [2 / (1.27 + 1)]^{[1.27 / (1.27 - 1)]}$$

$$= 42.8 \text{ psia}$$

Backpressure is less than P<sub>cf</sub>, so critical flow will occur.

Choose critical flow equation from p. 14 that uses "scfm" for flow units. Assume lowest K<sub>d</sub> for applicable pressure range from listing at top of this page (i.e., use K<sub>d</sub> for 2x3 and 3x4):

$$A = \frac{V \sqrt{MTZ}}{6.32CK_dP_1K_bK_c}$$

$$= \frac{8,000 \sqrt{(19)(460 + 80)(0.95)}}{6.32(344)(0.820)(77.7)(1)(1)} = 5.70 \text{ in}^2$$

**Select 3 x 4 F70PR with 7.402 in<sup>2</sup> orifice.** If a valve size with a different K<sub>d</sub> factor had been a match, the above calculation would be repeated with the proper coefficient.

NOTE: The Flow Safe relief valve sizing program "FlowSize" can be downloaded from our Web site. Locally trained representatives and factory personnel can also help with sizing.

## SIZING FOR GAS & VAPOR SERVICE (cont'd)

### Common Gas Properties

Gas	Molecular Weight	Specific Heat Ratio, $k (C_p/C_v)$	Gas Constant, C	Gas	Molecular Weight	Specific Heat Ratio, $k (C_p/C_v)$	Gas Constant, C
Acetylene	26	1.28	345	Hydrogen Sulfide	34	1.32	349
Air	29	1.40	356	Isobutane	58	1.10	327
Ammonia	17	1.30	347	Isopentane	72	1.08	325
Argon	40	1.66	377	Methane	16	1.31	348
Benzene	78	1.12	329	Methyl Chloride	50	1.20	337
n-Butane	58	1.09	326	Natural Gas	19	1.27	344
Carbon Dioxide	44	1.29	346	Nitrogen	28	1.40	356
Chlorine	71	1.36	353	Oxygen	32	1.40	356
Ethane	30	1.19	336	n-Pentane	72	1.08	325
Ethylene	28	1.24	341	Propane	44	1.13	330
Helium	4	1.66	377	Propylene	42	1.15	332
n-Hexane	86	1.06	322	Sulfur Dioxide	64	1.27	344
Hydrogen	2	1.41	357	Water vapor / steam	18	1.33	350

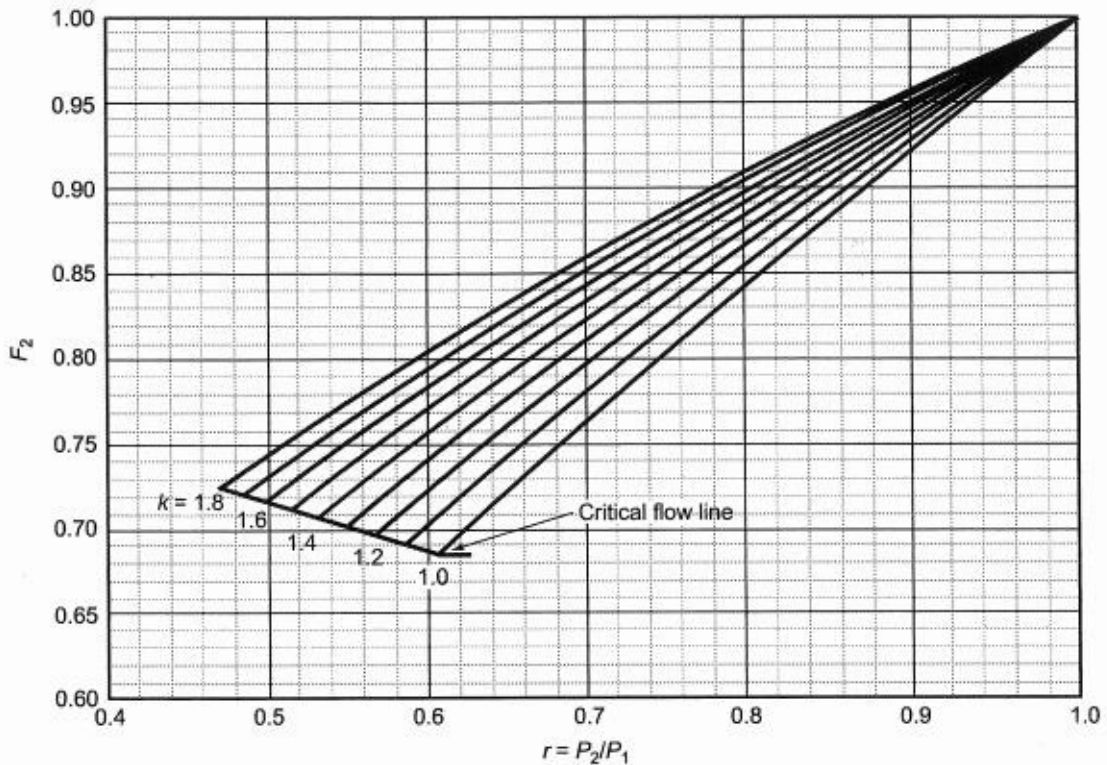

### Values of $F_2$ for Subcritical Flow

(For equations on p. 14)

# CAPACITIES

## F70PR Series

SCFH @ 5% Overpressure, 0 BP, 60 °F, Z=1.0, MW=29

AIR

Valve Size:	1-1/2 x 2	2 x 3	3 x 4	4 x 6	6 x 8	8 x 10	10 x 12	12 x 16
Orifice Area (in <sup>2</sup> ):	1.770	3.365	7.402	11.43	26.06	45.66	71.85	111.87
Cv:	46	79	174	269	614	1076	1692	2635
10 in wc	6612	12570	27650	42700	97350	170570	—	—
15 in wc	8094	15389	33850	52270	119170	208810	—	—
20 in wc	9342	17760	39070	60330	137550	241000	—	—
25 in wc	10440	19840	43660	67420	153710	269330	—	—
1 psig	10987	20880	45940	70950	161770	283440	—	—
5 psig	24394	46370	102010	158190	360680	631950	994400	1547300
10 psig	36230	68880	151510	254370	579960	1016150	1599000	2488000
15 psig	46530	88290	194210	344340	785090	1375500	2164500	3370200
20 psig	56200	105260	231560	403710	920450	1612700	2537700	3951300
30 psig	76410	140130	308260	522450	1191170	2087000	3284100	5113400
40 psig	93770	171980	378320	641190	1461900	2561400	4030600	6275600
50 psig	111140	203830	448380	759930	1732600	3035700	4777000	7437700
60 psig	128500	235680	518440	878670	2003300	3510000	5523400	8599900
80 psig	163240	299380	658560	1116150	2544700	4458700	7016200	10924200
100 psig	197970	363080	798680	1353630	3086200	5407400	8509000	13248500
120 psig	232700	426780	938800	1591100	3627600	6356000	10001800	15572800
140 psig	267430	490480	1078920	1828500	4169100	7304700	11494600	17897100
160 psig	302160	554180	1219000	2066000	4710500	8253400	12987400	20221400
180 psig	336900	617880	1359100	2303500	5252000	9202100	14480300	22545700
200 psig	371630	681580	1499200	2541000	5793400	10150700	15973100	24870000
220 psig	406360	745280	1639400	2778500	6334900	11099400	17465900	27194300
240 psig	441090	808980	1779500	3015900	6876300	12048100	18958700	29518600
260 psig	475820	872680	1919600	3253400	7417700	12996700	20451500	31842900
285 psig	519240	952300	2094700	3550300	8094500	14182600	22317500	34748300

SCFH @ 5% Overpressure, 0 BP, 60 °F, Z=1.0, MW=19

NATURAL GAS

Valve Size:	1-1/2 x 2	2 x 3	3 x 4	4 x 6	6 x 8	8 x 10	10 x 12	12 x 16
Orifice Area (in <sup>2</sup> ):	1.770	3.365	7.402	11.43	26.06	45.66	71.85	111.87
Cv:	46	79	174	269	614	1076	1692	2635
10 in wc	8157	15508	34110	52670	120100	210440	—	—
15 in wc	9979	18970	41730	64440	146930	257440	—	—
20 in wc	11510	21880	48130	74330	169470	296930	—	—
25 in wc	12850	24430	53750	83000	189250	331600	—	—
1 psig	13520	25700	56550	87320	199100	348850	—	—
5 psig	29630	56340	123930	192180	438170	767720	1208000	1879700
10 psig	43440	82600	181690	305040	695480	1218500	1917500	2983700
15 psig	55540	105400	231850	411070	937240	1642100	2584000	4023300
20 psig	67090	125660	276430	481950	1098800	1925200	3029600	4717000
30 psig	91210	167290	368000	623700	1422000	2491500	3920600	6104400
40 psig	111950	205320	451640	765450	1745200	3057800	4811700	7491800
50 psig	132680	243340	535270	907200	2068400	3624000	5702700	8879100
60 psig	153410	281360	618910	1048950	2391500	4190300	6593800	10266500
80 psig	194870	357400	786190	1332460	3037900	5322800	8375900	13041300
100 psig	236330	433450	953460	1615900	3684300	6455300	10158000	15816000
120 psig	277800	509490	1120740	1899400	4330700	7587800	11940200	18590800
140 psig	319260	585540	1288010	2182900	4977000	8720400	13722300	21365500
160 psig	360720	661580	1455200	2466400	5623400	9852900	15504400	24140300
180 psig	402190	737620	1622500	2749900	6269800	10985400	17286500	26915000
200 psig	443650	813670	1789800	3033400	6916200	12117900	19068600	29689800
220 psig	485110	889710	1957100	3316900	7562500	13250400	20850800	32464500
240 psig	526570	965760	2124300	3600400	8208900	14383000	22632900	35239300
260 psig	568040	1041800	2291600	3883900	8855300	15515500	24415000	38014000
285 psig	619870	1136800	2500700	4238300	9663300	16931100	26642600	41482500

# PART NUMBERING

**F70PR Series**

**P 70 H P - 0 4 R F 1 - 0 6 R F 1 - C S - A L - V V P T F H**

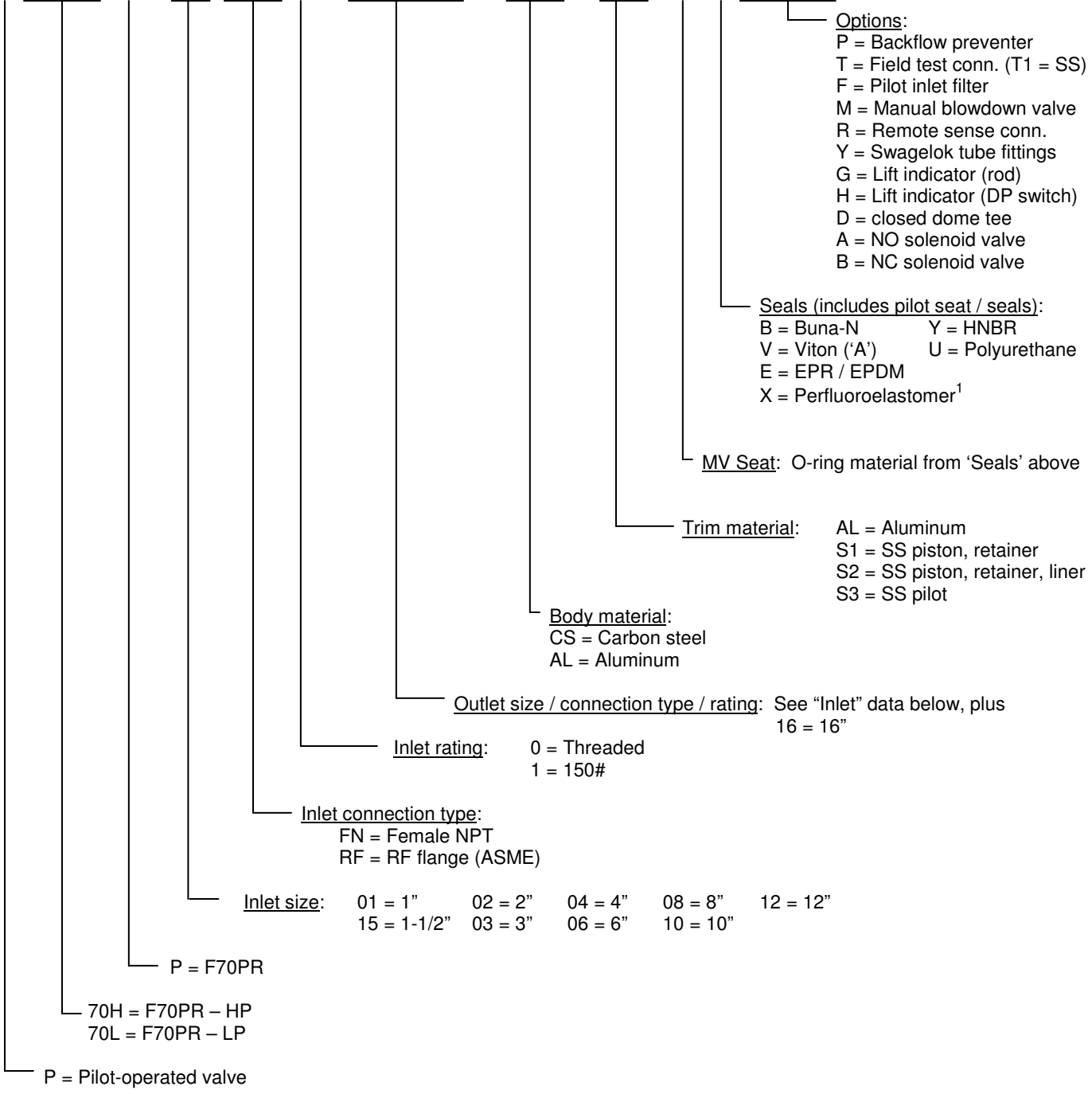

<sup>1</sup> Unless otherwise specified, Kalrez (Code Z), Chemraz (Code C), Perlast (Code M), or similar grade will be furnished.

## SAMPLE SPECIFICATION SHEET

Please include data as shown in the following table when contacting Flow Safe or their representatives regarding a relief valve application:

SERVICE CONDITIONS	Quantity	each
	Valve identification / tag number(s)	
	Delivery time	weeks
	Service media / fluid state	
	Molecular weight (gases)	
	Compressibility factor (gases)	
	Specific heat ratio (gases)	
	Specific gravity (liquids)	
	Viscosity (liquids)	
	Required capacity	scfm (Nm <sup>3</sup> /hr) lb/hr (kg/hr) gpm (lpm)
	Set pressure	psig barg kPag
	Allowable overpressure	% or psi/bar/kPa
	Backpressure	psig barg kPag
	Required blowdown	% or psi/bar/kPa
	Relieving temperature (at relief valve location)	°F or °C
	Normal operating temperature (at relief valve location)	°F or °C
System design temperature	°F or °C	
Required cleanliness level		
VALVE SELECTION	Body / bonnet material	
	Trim (wetted internals) material	
	Seat and seal material	
	Size and ASME Class for inlet / outlet	
	Flange facing, inlet/outlet	
	Special inlet / outlet	
	Orifice area calculated / selected	
	Valve part number (optional - see p. 18)	
	Accessories (see pp. 12 - 13)	

# Experts in Soft-Seated Technology



**F84/85/88 Series**  
Safety Relief Valve (Gas) - ASME VIII



**F84L/88 Series**  
Liquid Relief Valve - ASME VIII



**F70U Series**  
Unloader Valve



**F9000 Series**  
Liquid Surge Relief



**F7000/8000 Series**  
Pilot-Operated Relief Valve -  
ASME VIII

Leaders in "true" High Performance with  
commitment to value through:

- 24/7 service, repair, and support
- Soft seats offering unsurpassed tightness
- Large coefficients and orifice areas = Best capacities
- Backpressure-balanced without bellows
- ASME Sec. VIII, API, DOT, ISO 9001, CE, Marine class societies (e.g., DNV, BV)
- Trained representatives with solid factory support
- Quick-ship program through Flow Safe Supply



**FLOW SAFE**

*High Performance Safety Relief Valves*

**YOUR AUTHORIZED  
REPRESENTATIVE**

Executive Office  
3865 Taylor Road  
Orchard Park, NY 14127  
(716) 662-2585  
(716) 662-2580 Fax

Houston Office  
10727 Tower Oaks Blvd.  
Houston, TX 77070  
(832) 678-2070  
(716) 662-2580 Fax

www.flowsafe.com  
Inquiries: info@flowsafe.com