



## Two Piece Direct-Mount Automation Series



### FEATURES:

**Forged Brass Full Port  
Low Torque Design**

**Pressure:  
600 WOG - 150 WSP**

**Temperature:  
to 366°F**

**Sizes Range:  
1/4" thru 4"**



### Two Piece Direct Mount Series

STANDARD PRODUCT NUMBER

**DM51-BZ-TTT  
DM52-BZ-TTT**

### MODELS:

**DM51 - Brass-Plated Ball  
DM52 - 316SS Ball / Stem**

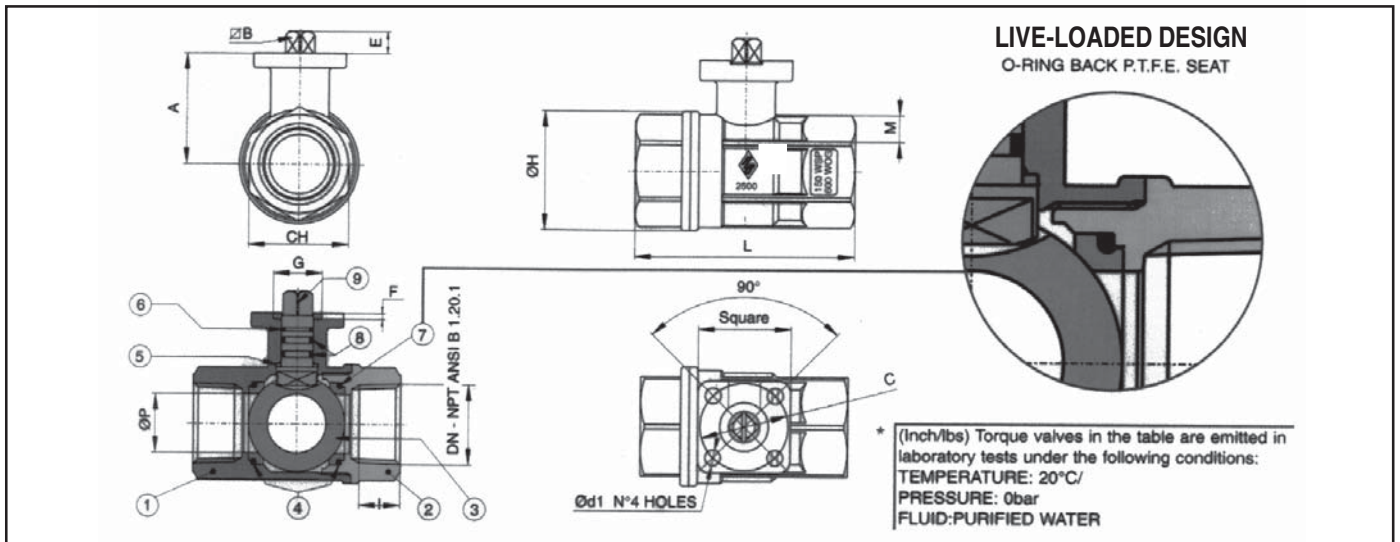

No. Pos	Part Name	Materials	N PCS
1	Body	Brass CW617N UNI EN 12165	1
2	End Cap	Brass CW617N UNI EN 12165	1
3	Ball	Brass CW617N UNI EN 12165	1
4	Seals #	P.T.F.E	2
5	Thrust Washer #	P.T.F.E	1
6	Stem Seal #	P.T.F.E	1
7	O-Rings #	FKM (Viton)	2
8	O-Rings #	FKM (Viton)	2
9	Stem	Brass CW617N UNI EN 12165	1

SIZE	SQUARE	A	∠B	C	Ød1	E	F	ØG	ØH	I	L	CH	M	ØP	PSI	Lbs	Inch/lbs	ISO 5211
1/4"	1.49	1.28	0.35	1.42	0.24	0.35	0.08	0.98	1.32	0.39	2.64	1.06	0.22	0.39	600	0.82	53.10	F03
3/8"	1.49	1.28	0.35	1.42	0.24	0.35	0.08	0.98	1.32	0.40	2.64	1.06	0.22	0.39	600	0.79	53.10	F03
1/2"	1.49	1.28	0.35	1.42	0.24	0.35	0.08	0.98	1.32	0.53	2.64	1.06	0.22	0.56	600	0.66	53.10	F03
3/4"	1.49	1.28	0.35	1.42	0.24	0.35	0.08	0.98	1.57	0.55	3.00	1.26	0.22	0.75	600	0.91	53.10	F03
1"	1.49	1.79	0.35	1.42	0.24	0.35	0.12	0.98	1.93	0.66	3.35	1.61	0.24	0.95	600	1.55	53.10	F03
1 1/4"	1.49	1.93	0.35	1.42	0.24	0.35	0.12	0.98	2.30	0.66	3.66	1.97	0.24	1.18	600	2.14	53.10	F03
1 1/2"	1.96	2.52	0.43	1.97	0.27	0.43	0.12	1.38	2.87	0.66	4.13	2.16	0.39	1.49	600	3.71	150.45	F05
2"	1.96	2.88	0.43	1.97	0.27	0.43	0.12	1.38	3.60	0.70	4.80	2.75	0.31	1.97	600	5.52	150.45	F05
2 1/2"	2.75	3.48	0.55	2.76	0.35	0.59	0.12	2.16	4.51	0.93	6.10	3.54	0.35	2.52	600	8.83	274.35	F07
3"	2.75	3.85	0.55	2.76	0.35	0.59	0.12	2.16	5.35	1.01	6.89	4.13	0.35	3.00	600	13.29	274.35	F07
4"	2.75	4.59	0.67	2.76	0.35	0.69	0.12	2.16	6.53	1.09	8.03	5.12	0.33	3.74	600	21.54	646.05	F07

# Parts included in repair kits

Flo-Tite's "DM" design eliminates mounting brackets and all their possible related problems. Ideally designed for low profile, cost effective industrial applications.



## Two Piece Direct-Mount Automation Series

**MODEL: DM80SS**

**FEATURES:**



**Stainless - Full Port  
Low Torque Design**

**Temperature:  
to 370°F**

**Pressure:  
1000 WOG - 150 WSP**

**Sizes Range:  
1/4" thru 2"**

**High Quality Investment Casting**

**Part ID'S  
DM80-SS-TTT**

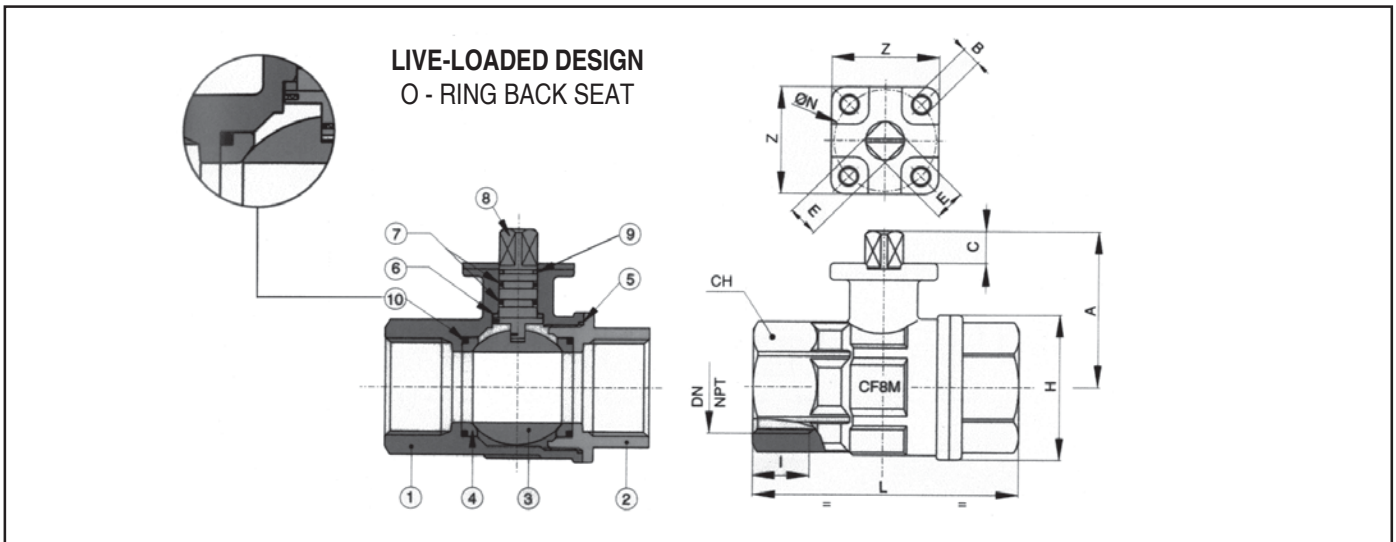

No. Pos	Part Name	Materials	N P C S
1	Body	Brass CW617N UNI EN 12165	1
2	End Cap	Brass CW617N UNI EN 12165	1
3	Ball	Brass CW617N UNI EN 12165	1
4	Seals #	P.T.F.E	2
5	Seat #	P.T.F.E	1
6	Stem Seal #	P.T.F.E	1
7	O-Rings #	FKM (Viton)	2
8	Stem	AISI 316 - CF8M	1
9	Stem Seat #	P.T.F.E	1
10	O-Ring #	FKM (Viton)	1

SIZE	A	B	C	CH	E	H	I	L	N	Z	Cv	Torque in-lb	Weight Lbs	ISO 5211
1/2"	1.63	0.23	0.35	1.06	0.35	1.35	0.59	2.63	1.41	1.49	16.3	60	0.68	F03
3/4"	1.71	0.23	0.35	1.25	0.35	1.65	0.64	3.07	1.41	1.49	29.5	64	0.91	F03
1"	2.10	0.23	0.35	1.61	0.35	2.02	0.75	3.54	1.41	1.49	43.0	68	1.35	F03
1 1/4"	2.24	0.23	0.35	1.96	0.35	2.53	0.84	3.93	1.41	1.49	89.0	74	2.22	F03
1 1/2"	2.91	0.27	0.43	2.16	0.43	3.03	0.84	4.40	1.96	1.96	230.0	160	3.69	F05
2"	3.27	0.27	0.43	2.75	0.43	3.81	1.01	5.31	1.96	1.96	265.0	170	6.69	F05

# Parts included in repair kits

Flo-Tite's "DM" design eliminates mounting brackets and all their possible related problems. Ideally designed for low profile, cost effective industrial applications.



Flo-Tite, Inc.  
4815 West 5th St.  
Lumberton, NC 28358

P. O. Box 1293  
Lumberton, NC 28359  
Website: www.flotite.com

Tel: (910) 738-8904  
Fax: (910) 738-9112  
E-mail: flotite@flotite.com